



A Division of Systems, LLC

HP/H Series

Dock Leveler

Owner's/User's Manual



McGuire • Division of Systems, LLC • W194 N11481 McCormick Drive • Germantown, WI 53022
800.624.8473 • fax: 262.255.5917 • www.wbmcguire.com • techservices@loadingdocksystems.com

Printed in U.S.A.
© 2018 Systems, LLC - All Rights Reserved

Manual No. 4111-0018
Sept. 2018

Table of Contents

	Page
Precautions	
Recognize Precautionary Information	1
General Operational Precautions	1
Operational Precautions	2
Safety Decals.....	4
Placard	5
Owner's/User's Responsibilities	6
Introduction	
General Information.....	8
Component Identification.....	9
Installation	
Installation Precautions	10
Prepare Pit.....	12
Prepare Dock Leveler	13
Install Dock Leveler	14
Install Control Panel and Wiring	20
Put New Dock Leveler Into Service.....	26
Operation	
Operational Precautions	27
Operating Instructions	28
Optional Equipment.....	30
Maintenance	
Maintenance Precautions.....	31
Periodic Maintenance	32
Adjustments	
Adjust Hydraulic Pump	34
Adjust Auto Return To Dock (ARTD).....	36
Troubleshooting	
Troubleshooting.....	38
Hydraulic Schematic.....	42
Parts	
Danfoss Control Box	44
Optional Electrical Parts (Control Box)	45
Optional Electrical Parts (Lip Switch Assembly).....	46
Optional Electrical Parts (Hoist Switch Assembly)	47
Frame and Platform	48
Hydraulic Components.....	52
Weather Seals	54
Toe Guards	55
Miscellaneous	
Customer Information	57
Warranty.....	Back Cover

PRECAUTIONS

Recognize Precautionary Information

Safety-Alert Symbol



The Safety-Alert Symbol is a graphic representation intended to convey a safety message without the use of words. When you see this symbol, be alert to the possibility of death or serious injury. Follow the instructions in the safety message panel.

DANGER

The use of the word DANGER signifies the presence of an extreme hazard or unsafe practice which will most likely result in death or severe injury.

WARNING

The use of the word WARNING signifies the presence of a serious hazard or unsafe practice which could result in death or serious injury.

CAUTION

The use of the word CAUTION signifies possible hazard or unsafe practice which could result in minor or moderate injury.

NOTICE

The use of the word NOTICE indicates information considered important, but not hazard-related, to prevent machine or property damage.

SAFETY INSTRUCTIONS

Indicates a type of safety sign, or separate panel on a safety sign, where safety-related instructions or procedures are described.

General Operational Precautions

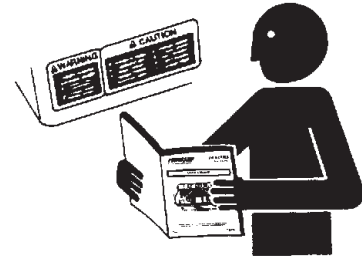

Read and understand the Owner's/User's Manual and become thoroughly familiar with the equipment and its controls before operating the dock leveler.

Never operate a dock leveler while a safety device or guard is removed or disconnected.

Never remove DANGER, WARNING, or CAUTION signs, Placards or Decals on the equipment unless replacing them.

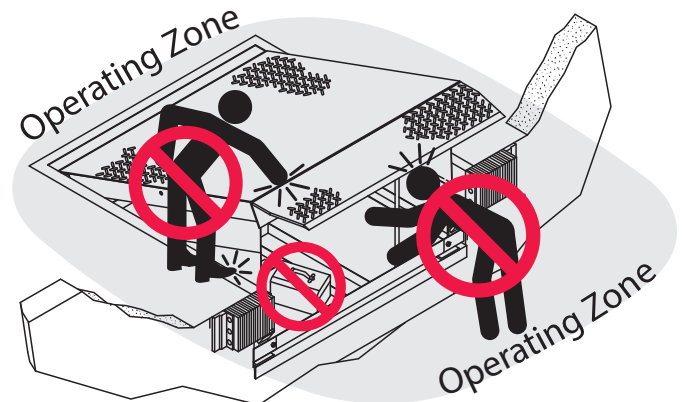

Figure 1

Do not start the equipment until all unauthorized personnel in the area have been warned and have moved outside the operating zone (see Figure 1).

Remove any tools or foreign objects from the operating zone before starting.

Keep the operating zone free of obstacles that could cause a person to trip or fall.



WARNING: This product can expose you to chemicals including lead, which are known to the State of California to cause cancer or birth defects or other reproductive harm. For more information go to www.P65Warnings.ca.gov

PRECAUTIONS

Operational Precautions



Learn the safe way to operate this equipment. Read and understand the manufacturer's instructions. If you have any questions, ask your supervisor.

DANGER



Stay clear of dock leveling device when transport vehicle is entering or leaving area.



Do not move or use the dock leveling device if anyone is under or in front of it.



Keep hands and feet clear of pinch points. Avoid putting any part of your body near moving parts.

WARNING



Chock/restrain all transport vehicles. Never remove the wheel chocks or release the restraining device until loading or unloading is finished, and transport driver has been given permission to drive away.



Do not use a broken or damaged dock leveling device or restraining device. Make sure proper service and maintenance procedures have been performed before using.

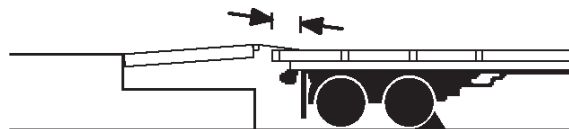

Make sure lip overlaps onto transport vehicle bed at least 4 in. (102 mm).

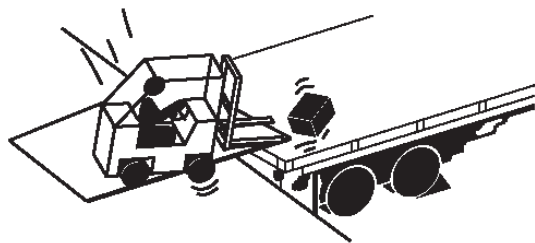

Keep a safe distance from both side edges.

Operational Precautions

! WARNING

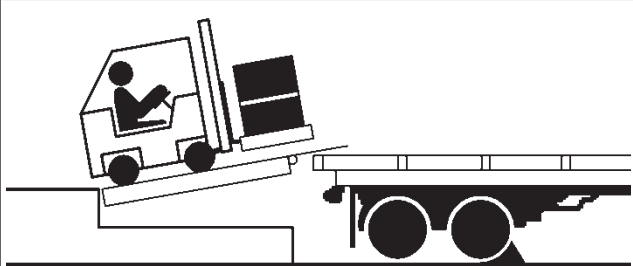

Do not use dock leveling device if transport vehicle is too high or too low.

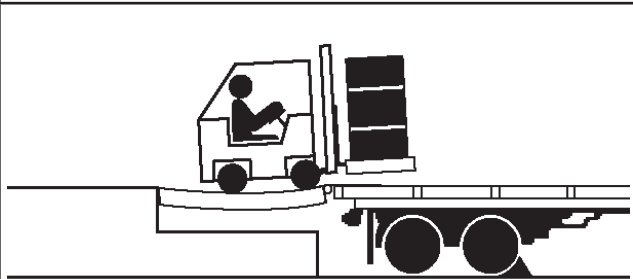

Do not overload the dock leveling device.



Do not operate any equipment while under the influence of alcohol or drugs.

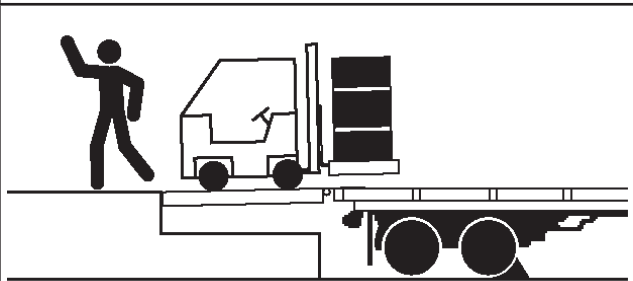

Do not leave equipment or material unattended on dock leveling device.

PRECAUTIONS

Safety Decals



1751-0329



1751-0330 Two positions one on top of each fork pocket.

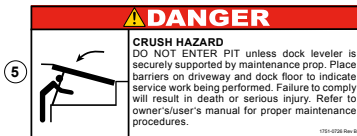

1751-0726

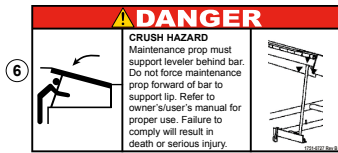

1751-0727



1751-0729



1751-0138

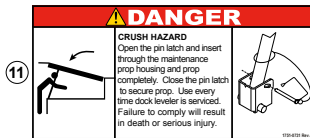

1751-0731

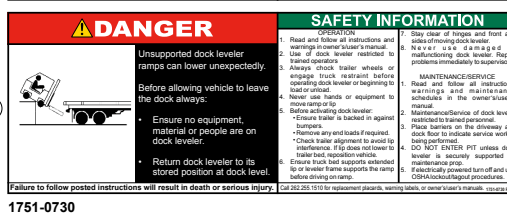
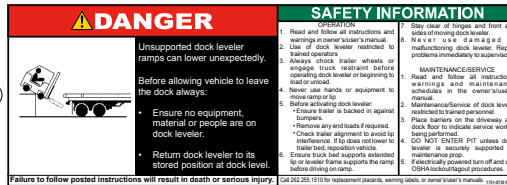

1751-0730

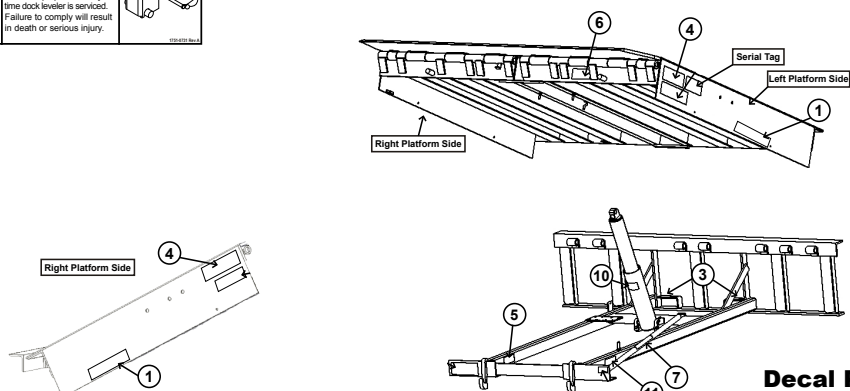



Figure 2

Decal Placement for H Series

Placard



DANGER

OPERATING INSTRUCTIONS

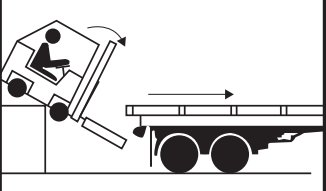

- Read and follow all instructions, warnings, and maintenance schedules in the manual and on placards.
- Operation and servicing of dock leveler is restricted to authorized personnel.

- Always chock transport vehicle wheels or engage vehicle restraint and set parking brakes before operating dock leveler or beginning to load or unload.
- Before activating dock leveler, check to make sure the transport vehicle is positioned squarely against dock bumpers. Ensure lip will avoid contact with transport vehicle frame, sides and cargo during dock leveler activation. If contact is likely or observed, reposition transport vehicle.
- Ensure the transport vehicle floor supports extended lip or the leveler frame (lip keepers or below dock endload supports) supports the ramp before driving on ramp.
- Stay clear of hinges and front and sides of moving dock leveler.
- Never use hands or equipment to move the ramp or lip.
- Never use damaged or malfunctioning dock leveler. Report problems immediately to supervisor.
- Always store dock leveler and remove people, material, and equipment from ramp before vehicle leaves the dock.
- DO NOT ENTER PIT unless dock leveler is securely supported and proper lockout/tagout procedures have been completed. See "Maintenance Precautions" in Owner's/User's Manual.

FAILURE TO FOLLOW THESE INSTRUCTIONS WILL RESULT IN DEATH OR OTHER SERIOUS INJURY.

POWERED DOCK LEVELERS

NORMAL OPERATION

1. Raise the platform by Pressing and holding the RAISE button.
2. Hold the RAISE button until the lip is fully extended, then release the RAISE button. The platform will lower until lip is resting on the transport vehicle.

STORING LEVELER

1. Press the RAISE button until the lip is completely folded. When the lip is folded, release the RAISE button. The platform will lower returning to the cross-traffic position.

BELOW DOCK ENDLOADING

- (AIR POWERED ONLY)** Press and hold the RAISE button until the leveler is 12" above dock level. Pull the below dock level chain until the leveler lowers the full below dock position.
- (HYDRAULIC ONLY)** Press and hold the RAISE button until the leveler is fully raised. As the lip starts to extend, release the RAISE button. The leveler will lower to the below dock position provided the lip extension allows the lip to clear the lip keepers.
- (HYDRAULIC WITH INFINITE LIP CONTROL)** If equipped, raise the platform by Pressing and holding the RAISE button. When the lip is just above the lip keepers, simultaneously Press and hold the RAISE button and the LIP OUT button until lip has extended beyond the lip keepers. Release both buttons.



Scan to view our owner's/user's manuals online.
www.LoadingDockSystems.com
1.800.643.5424
 Call for additional placards, or manuals, or with questions regarding proper use, maintenance, and repair of dock leveler.



WARNING: CANCER AND REPRODUCTIVE HARM
www.P65Warnings.ca.gov

1751-0874 Rev D

NOTE: If equipped, Pressing E-STOP button will stop platform from lowering.

1751-0874

4111-0018 — Sept. 2018
 © 2018 Systems, LLC

5

OWNER'S/USER'S RESPONSIBILITIES

- 1) The manufacturer shall provide to the initial purchaser and make the following information readily available to the owners/users and their agents, all necessary information regarding Safety Information, Operation, Installation and Safety Precautions, Recommended Initial and Periodic Inspections Procedures, Planned Maintenance Schedule, Product Specifications, Troubleshooting Guide, Parts Break Down, Warranty Information, and Manufacturers Contact Information, as well as tables to identify the grade(slope) for all variations of length or configuration of the dock leveling device and information identifying the maximum uncontrolled drop encountered when sudden removal of support while in the working range of the equipment.
- 2) When selecting loading dock safety equipment, it is important to consider not only present requirements but also future plans and any possible adverse conditions, environmental factors or usage. The owners/users shall provide application information to the manufacturer to receive recommendations on appropriate equipment specifications and capacity.
- 3) The owner/user must see all nameplates, placards, decals, instructions and posted warnings are in place and legible and shall not be obscured from the view of the operator or maintenance personnel for whom such warnings are intended for. Contact manufacturer for any replacements.
- 4) Dock leveling devices may become hazardous if the manufacturer's instructions regarding modifications or adjustments are not followed. Modifications or alterations of dock leveling devices shall only be made with prior written approval from the original manufacturer. These changes shall be in conformance with all applicable provisions of the MH30.1 standard and shall also satisfy all safety recommendations of the original equipment manufacturer of the particular application.
- 5) The owner/user should recognize the inherent dangers of the interface between the loading dock and the transport vehicle. The owner/ user should, therefore, train and instruct all operators in the safe operation and use of the loading dock equipment in accordance with manufacturer's recommendations and industry standards. Effective operator training should also focus on the owner's/user's company policies, operating conditions and the manufacturer's specific instructions provided with the dock leveling device. Maintaining, updating and retraining all operators on safe working habits and operation of the equipment, regardless of previous experience, should be done on a regular basis and should include an understanding and familiarity with all functions of the equipment. Owners/users shall actively maintain, update and retrain all operators on safe working habits and operations of the equipment.
- 6) An operator training program should consist of, but not necessarily be limited to, the following:
 - a) Select the operator carefully. Consider the physical qualifications, job attitude and aptitude.
 - b) Assure that the operator reads and fully understands the complete manufacturer's owners/users manual.
 - c) Emphasize the impact of proper operation upon the operator, other personnel, material being handled, and equipment. Cite all rules and why they are formulated.
 - d) Describe the basic fundamentals of the dock leveling device and components design as related to safety, e.g., mechanical limitation, stability, functionality, etc.
 - e) Introduce the equipment. Show the control locations and demonstrate its functions. Explain how they work when used properly and maintained as well as problems when they are used improperly.
 - f) Assure that the operator understands the capacity rating, nameplate data, placards and all precautionary information appearing on the dock leveling device.
 - g) Supervise operator practice of equipment.
 - h) Develop and administer written and practical performance tests. Evaluate progress during and at completion of the course.
 - i) Administer periodic refresher courses. These may be condensed versions of the primary course and include on-the-job operator evaluation.

OWNER'S/USER'S RESPONSIBILITIES

- 7) Loading dock safety equipment should never be used outside of its vertical working range, or outside the manufacturer's rated capacity. It shall also be compatible with the loading equipment and other conditions related to dock activity. Please consult the manufacturer if you have any questions as to the use, vertical working range or capacity of the equipment. Only properly trained and authorized personnel should operate the equipment.
- 8) It is recommended that the transport vehicle is positioned as close as practical to the dock leveling device and in contact with both bumpers. When an industrial vehicle is driven on or off a transport vehicle during loading and unloading operations, the transport vehicle parking brakes shall be applied and wheel chocks or a restraining device that provides equal or better protection of wheel chocks shall be engaged. Also, whenever possible, air-ride suspension systems should have the air exhausted prior to performing said loading and unloading operations.
- 9) When goods are transferred between the loading dock and a trailer resting on its support legs/ landing gear instead of a tractor fifth wheel or converter dolly, it is recommended that an adequate stabilizing device or devices shall be utilized at the front of the trailer.
- 10) In order to be entitled to the benefits of the standard product warranty, the dock safety equipment must have been properly installed, maintained and operated in accordance with all manufacturer's recommendations and/ or specified design parameters and not otherwise have been subject to abuse, misuse, misapplication, acts of nature, overloading, unauthorized repair or modification, application in a corrosive environment or lack of maintenance. Periodic lubrication, adjustment and inspection in accordance with all manufacturers' recommendations are the sole responsibility of the owner/user.
- 11) Manufacturer's recommended maintenance and inspection of all dock leveling devices shall be performed in conformance with the following practices: A planned maintenance schedule program must be followed, only trained and authorized personnel shall be permitted to maintain, repair, adjust and inspect dock leveling devices, and only the use of original equipment manufacturer parts, manuals, maintenance instructions, labels, decals and placards or their equivalent. Written documentation of maintenance, replacement parts or damage should be kept. In the event of damage, notification to the manufacturer is required.
- 12) Loading dock devices that are structurally damaged or have experienced a sudden loss of support while under load, such as might occur when a transport vehicle is pulled out from under the dock leveling device, shall be removed from service, inspected by a manufacturer's authorized representative, and repaired or replaced as needed or recommended by the manufacturer before being placed back in service.

INTRODUCTION

General Information



Figure 3

This manual provides current information on the HP/H-series dock leveler. Due to ongoing product improvement, some parts may have changed, along with operation and troubleshooting methods. This manual describes these changes where applicable.

The HP/H-series dock leveler comes equipped with an electrical control panel, which allows push button operation of the dock leveler functions. When combining a HP/H-series dock leveler with a McGuire hydraulic vehicle restraint, the control panel will allow for operation of both units in the same control panel.

Each HP/H-series dock leveler unit and control panel has been factory pre-wired and tested to ensure satisfactory operation.

To illustrate which connections are to be made in the field at installation, electrical drawings are included with each order or by contacting Systems, LLC Technical Services.

HP/H dock levelers are available in the following sizes, weight capacities, and options:

Width

6 ft (1828.8 mm)
6-1/2 ft (1981.2 mm)
7 ft (2133.6 mm)

Length

6 ft (1828.8 mm)
8 ft (2438 mm)
10 ft (3048 mm)
12 ft (3658 mm)

Capacity (CIR*)

25,000 lb (11 340 kg)
30,000 lb (13 608 kg)
35,000 lb (15 876 kg)
40,000 lb (18 144 kg)
45,000 lb (20 412 kg)
55,000 lb (24 948 kg)
75,000 lb (34 019 kg)
100,000 lb (45 359 kg)

* CIR (Comparative Industry Rating)

Call McGuire to discuss available voltages, phases and options to meet your specific needs.

Technical Service at 800-643-5424 or techservices@loadingdocksystems.com

Component Identification

Inspect package and all components. Report any missing or damaged items immediately and note on the shipping Bill Of Lading (BOL).

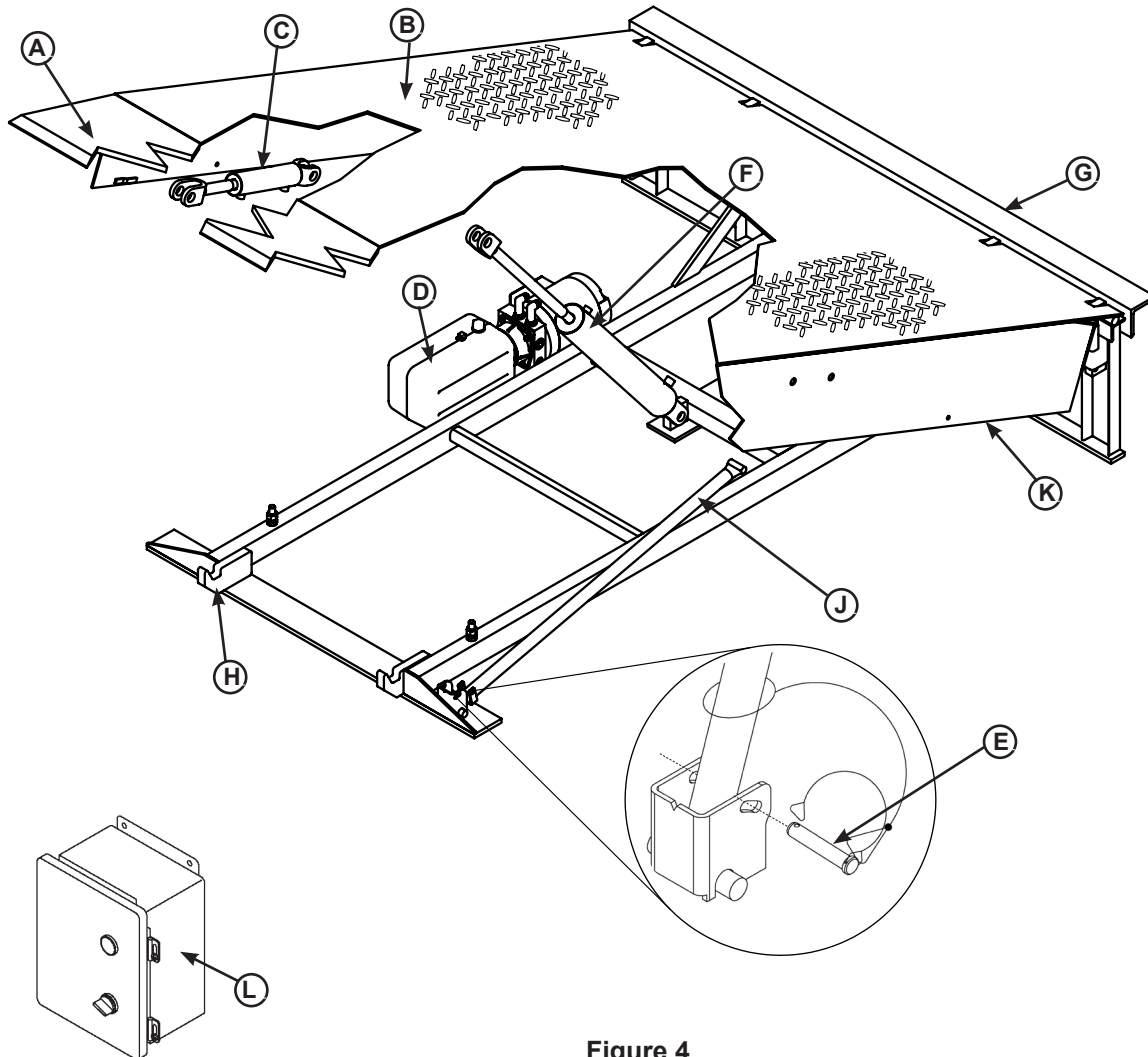

Figure 4

- | | | | |
|------------------|--------------------------------------|--------------------------|------------------------|
| A — Lip | D — Powerpack (Motor/Pump/Reservoir) | G — Main Frame | K — Toe Guard (2 used) |
| B — Platform | E — Prop Pin and Clip | H — Lip Keepers (2 used) | L — Control Box* |
| C — Lip Cylinder | F — Platform Cylinder | J — Maintenance Prop | |

* Control box appearance may vary depending on options.

INSTALLATION

Installation Precautions

DANGER

It is recommended and good safety practice to use an additional means to support the dock platform and lip anytime when physically working in front of or under the dock leveler. This additional means may include, but is not limited to a boom truck, fork truck, stabilizing bar or equivalent.

WARNING

Always post safety warnings and barricade the work area at dock level and ground level to prevent unauthorized use of the dock leveler before installation is complete.

A hard hat or other applicable head protection should always be worn when working under or around a dock leveler.

Always stand clear of platform lip when working in front of the dock leveler.

WARNING

DO NOT grind or weld if hydraulic fluid or other flammable liquid is present on the surface to be ground or welded.

DO NOT grind or weld if uncontained hydraulic fluid or other flammable liquid is present. Stray sparks can ignite spills or leaks near the work area. Always clean up the oil leaks and spills before proceeding with grinding or welding.

Always keep a fire extinguisher of the proper type nearby when grinding or welding.

CAUTION

Only trained installation professionals with the proper equipment should install this product.

NOTICE

DO NOT connect the dock leveler electrical wiring and ground connections until all welding has been completed.

DO NOT ground welding equipment to any hydraulic or electrical components of the dock leveler. Always ground welding equipment to the dock leveler frame, NEVER to the platform.

Failure to follow these instructions may damage the motor, hydraulics, wiring, and/or control panel.

NOTICE

DO NOT remove the shipping bands around the dock leveler lip until instructed to do so.

Leveler Forklift Pick-Up*

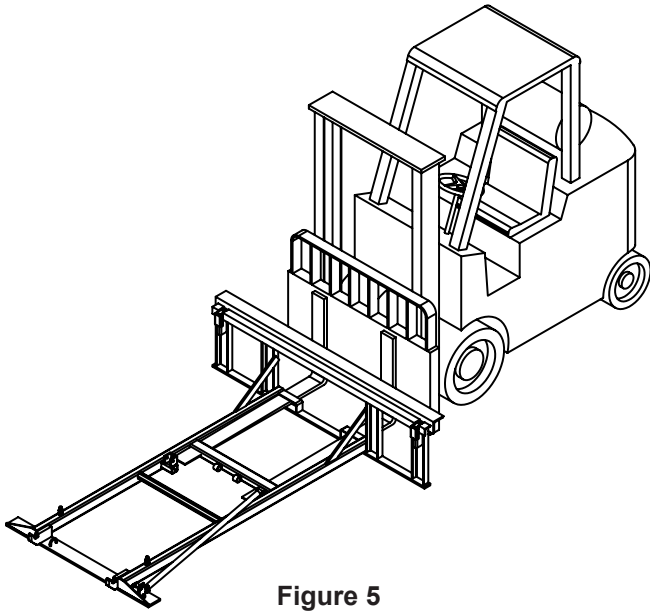

Figure 5

Rear Pick-Up (recommended)

To pick up the dock leveler from the rear, slide forks into the fork slots and under the cross member as shown in Figure 5.

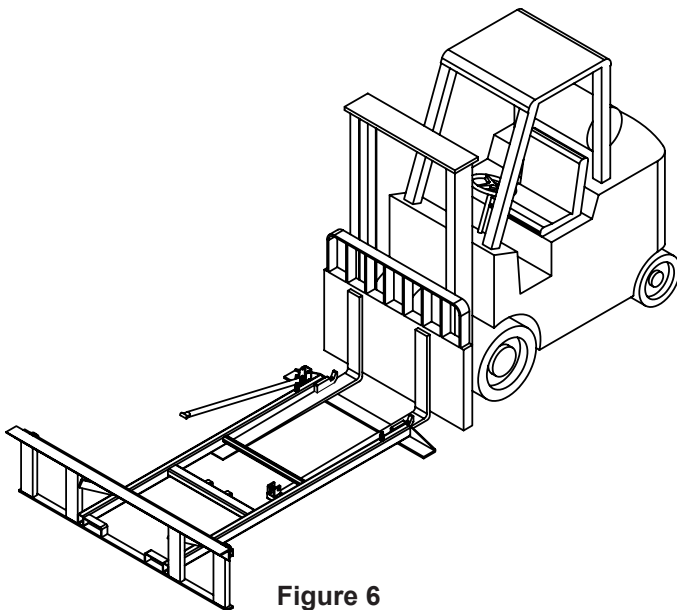

Figure 6

Front Pick-Up

To pick up the dock leveler from the front, move forks closer together and slide over the frame and under the crossmember as shown in Figure 6. It may be necessary to remove the shipping bands from the unit to gain access to the front, by lifting the lip up then sliding the forks under the cross member.

* Dock leveler platform not shown for clarity.

INSTALLATION

Prepare Pit

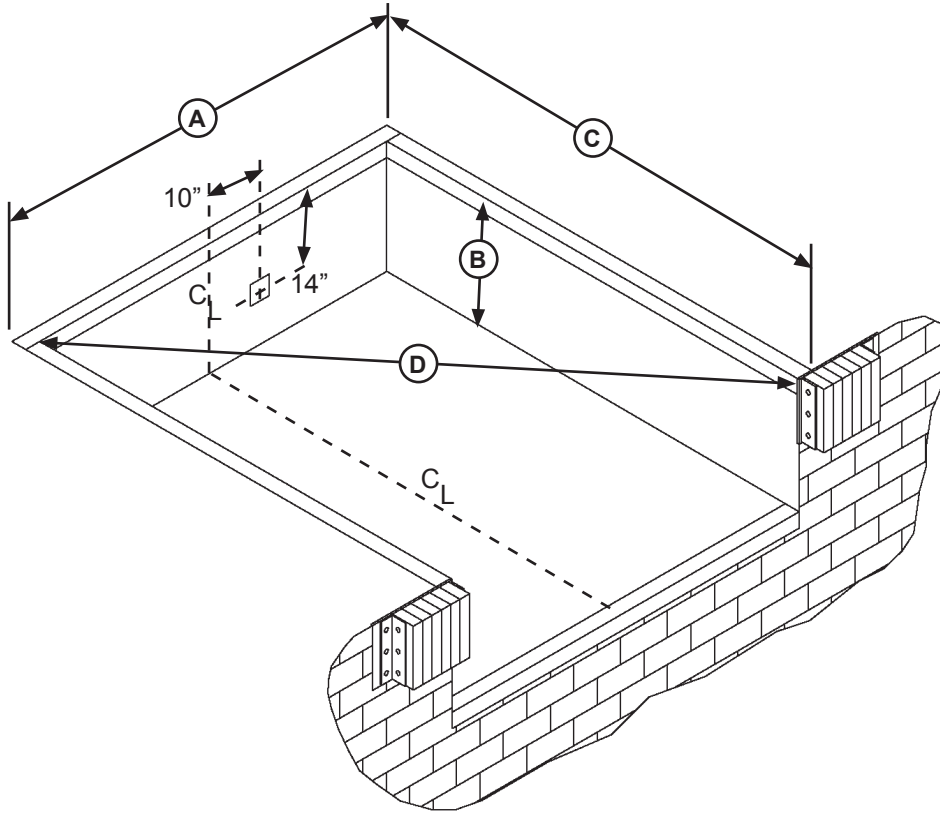

Figure 7

A—Pit Width
(Front and Rear)

B— Dock Floor-to-Pit Floor
(All Four Corners)

C— Pit Length
(Both Sides of Pit)

D— Pit Corner-to-Corner
(Top, Bottom, and Both Sides)

Before lowering the dock leveler into the pit, the following must be performed:

1. Remove all debris from the pit and sweep the pit clean.
2. Check the entire dock leveler pit for proper construction according to approved/certified pit drawings. Make sure pit is square by making the following measurements (see Figure 7):

- Measure pit width distance (A) at both front and rear of pit.
- Measure dock floor-to-pit floor distance (B) at all four corners.
- Measure pit length distance (C) at both sides.
- Measure corner-to-corner (diagonal) distance (D) at both sides. Take measurements at dock floor level and at pit floor level.

If any measurement is off by more than 1/8 in. (3.18 mm), contact Systems, LLC Technical Services before proceeding.

3. Make sure the field junction box for the dock leveler is at the correct location per pit diagrams.

Prepare Dock Leveler

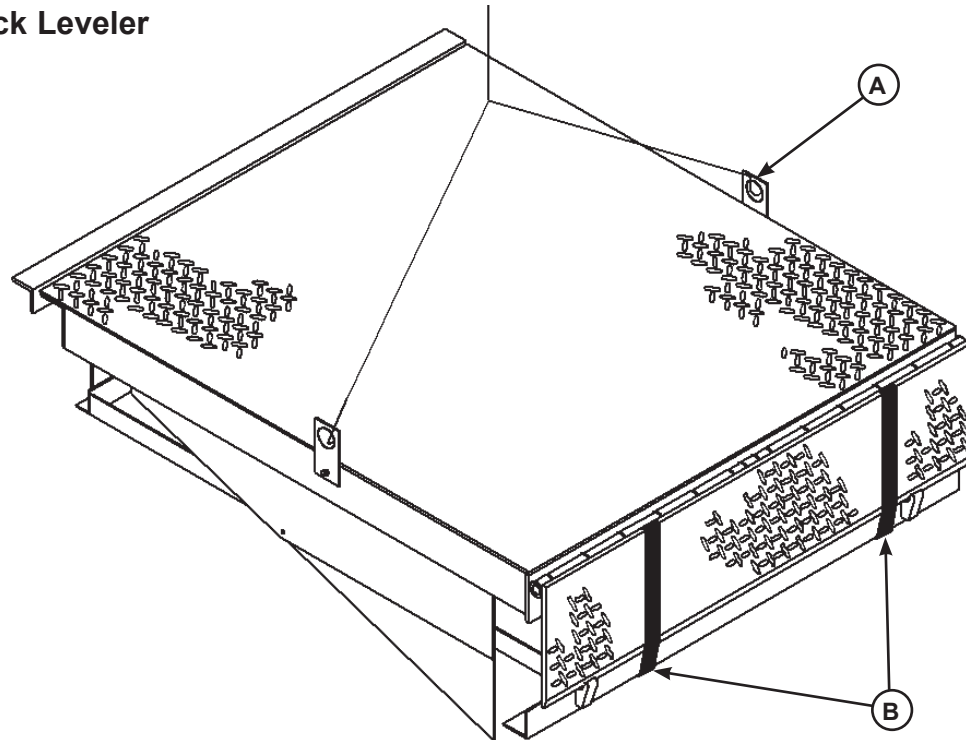

Figure 8

A— Lifting Bracket (2 used)

B — Shipping Bands

McGuire dock levelers are shipped with lifting brackets (A) fastened to the platform side joists, and shipping bands (B) around the platform lip and leveler frame (see Figure 8).

1. Remove any bumpers and/or control panels that may be banded to the frame of the dock leveler.

3. Attach lifting chains to lifting brackets (A) and to a lifting device (i.e., hoist or fork truck) having the appropriate lifting capacity and reach.

4. Remove wood blocks that are attached to the leveler frame before putting the dock leveler into the pit.

5. Proceed to “Install Dock Leveler” on Page 14.

NOTICE

DO NOT remove the shipping bands (B) around the platform lip and leveler frame at this time. The shipping bands are needed to hold the leveler together during the installation process.

Note: Overall width of platform and lifting brackets (A) must be kept to a minimum to prevent interference between the lifting brackets and the pit walls as the dock leveler is lowered into the pit.

2. Make sure the mounting hardware of lifting brackets (A) is snug. The brackets should pivot without binding on the mounting cap screw.

NOTICE

DO NOT over-tighten the lifting bracket hardware. Over-tightening can damage the weather seal, if equipped.

INSTALLATION

Install Dock Leveler

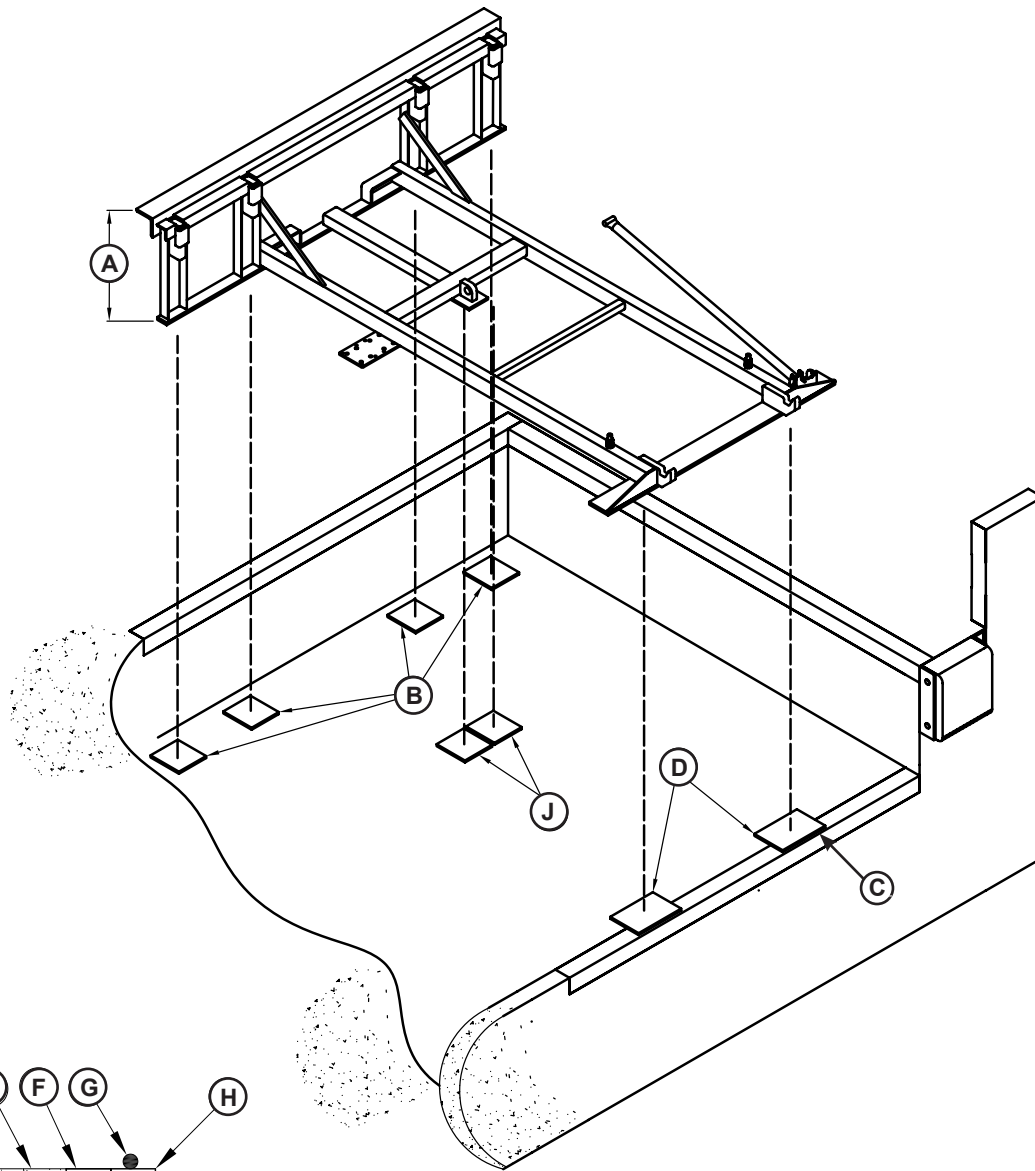

Figure 9

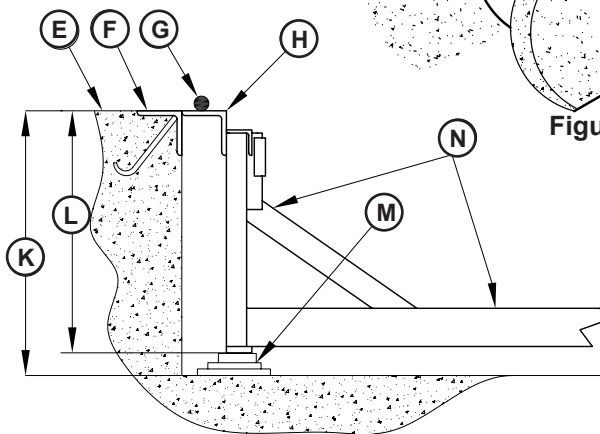

Figure 10

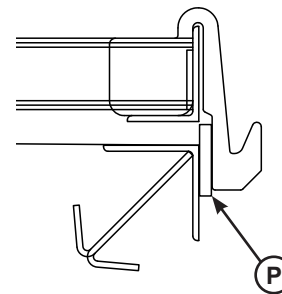

Figure 11

- | | | | |
|--|---------------------------------------|---|---|
| A— Distance (Leveler Frame Height) | D— Shim Locations (Under Lip Keepers) | H— Rear Hinge Frame Angle | L— Distance (Top of Shim Stack-to-Dock Floor) |
| B— Shim Locations (Under Rear Vertical Supports) | E— Dock Floor | J— Shims Location(Under Hoist Cylinder) | M— Shim Stack |
| C— Shim Location (Under Maintenance Prop) | F— Rear Pit Curb Angle | K— Distance (Dock Floor-to-Pit Floor) | N— Dock Leveler Frame |
| | G— String | | P— Lip Keeper Shim (as required) |

Install Dock Leveler (continued)

Note: McGuire dock levelers are designed with a nominal 1/2" (12.7 mm) shimming distance to allow for pit inconsistencies.

1. Determine height of shim stack (**M**) for each shim location (**B**) by performing the following:

- a. Measure leveler frame height distance (**A**).
- b. Measure dock floor-to-pit floor distance (**K**) at each shim location (**B**). Write down the dimensions obtained at each location.
- c. Subtract distance (**A**) from distance (**K**) to obtain the shim height. Repeat for each shim location.

2. Using the results obtained in step 1, create the individual shim stacks on the pit floor at location (**B**). Build each shim stack (**M**) with the top shim having a minimum size of 4-1/2" x 4-1/2" (114.3 mm x 114.3 mm) and each successive lower shim being larger so the shims can be welded together using a fillet weld. If using offset method, make sure load is over center of shim stack, NOT over the edge. DO NOT use straight method. See Figure 12.

NOTICE

The minimum size of the shim that contacts the leveler frame (i.e. the top shim of each shim stack) must be at least 4-1/2" x 4-1/2" (114.3 mm x 114.3 mm) to support the full width of the frame rail and to provide a shelf for a fillet weld.

Use the thickest shim stock possible for stability and weld penetration purposes. DO NOT use multiple layers of 1/8 in. (3.18 mm) or thinner shim stock.

Note: To assist in obtaining an accurate measurement of distance (**L**), use a string (**G**) pulled tight across the pit opening, directly over the shim locations.

3. Verify that each shim stack is at the correct height by measuring distance (**L**) [top of shim stack (**M**) to dock floor]. Distance (**L**) must equal the dock leveler height (**A**).

4. Put a 1/4 in. (6.6 mm) thick shim at locations (**C** and **D**).

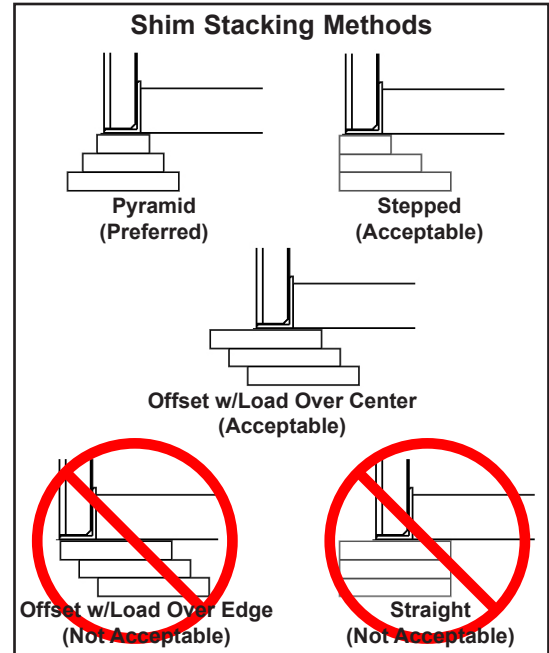

Figure 12

Note: A 1/4" (6.6 mm) thick shim at locations (**C** and **D**) are used only as a starting point. The final shim stack height will be determined after dock leveler is lowered into the pit.

5. Using an appropriate lifting device connected to the lifting brackets, lower dock leveler into the pit so rear hinge frame angle (**H**) is tight against rear pit curb angle (**F**) across full width of the leveler frame.

WARNING

The dock leveler is heavy. Use a lifting device and chains with the appropriate lifting capacity and reach.

Always use the lifting brackets provided with the unit whenever lowering or lifting a dock leveler into or out of a pit.

6. Allow rear of dock leveler to rest on the rear shims while keeping the front of the dock leveler level with the dock floor.

7. Add shims at front shim locations (**C** and **D**) so front of dock leveler will stay level with dock floor when leveler is resting fully on shims.

INSTALLATION

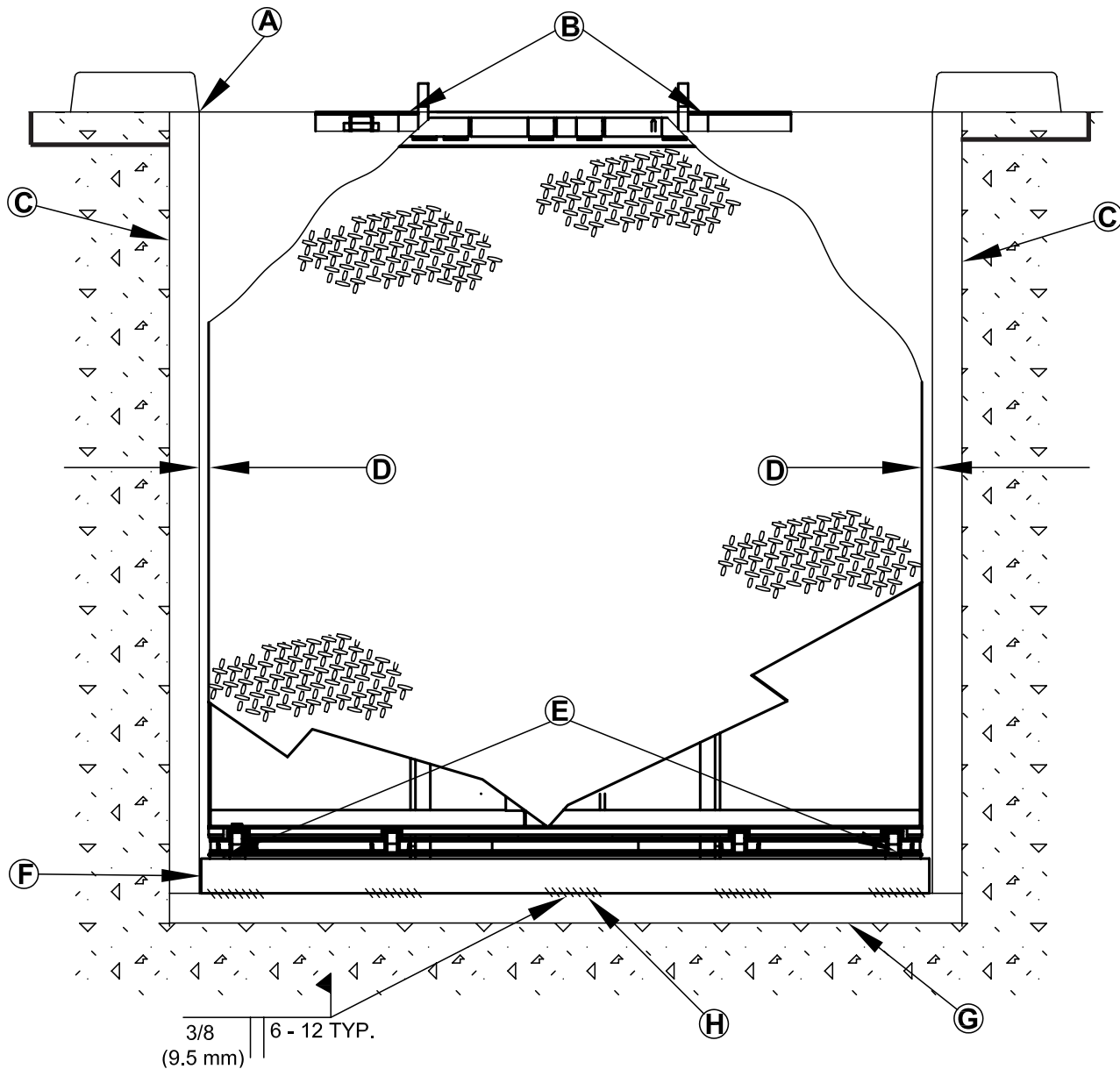

Figure 13

- | | | | |
|-----------------------|----------------------------------|---------------------------|---|
| A— Front of Dock Pit | C— Side Pit Curb Angle | E— Pry Locations | G— Rear Pit Curb Angle |
| B— Dock Leveler Frame | D— Gap [3/4 in. (19 mm) Minimum] | F— Rear Hinge Frame Angle | H— Flare Bevel Weld, Typical (To Fit Spacing) |

8. With rear hinge frame angle (F) tight against rear pit curb angle (G), perform/check the following:

- Pry between the platform and rear hinge frame angle at locations (E) to make sure rear edge of platform is parallel to the rear hinge frame angle (F).
- Gap (D) must exist equally along both sides of leveler so weather seal (if equipped) will not bind during dock leveler operation.

9. If gap (D) cannot be obtained equally at both sides of leveler, grind or add material at the rear edge of rear hinge frame angle (F) as needed.

10. Allow the dock leveler to rest fully on the shim stacks. Check that a smooth and level transition exists between the dock floor and the dock leveler platform. Add or remove shims as necessary until a smooth transition is obtained.

11. If leveler cannot be squared and/or made level as instructed in steps 8-10, contact Systems, LLC Technical Services.

Install Dock Leveler (continued)

NOTICE

DO NOT weld continuously along the full length of the rear hinge frame angle. This can put unnecessary stress on the leveler components, causing the leveler to malfunction and shorten the lifespan of the affected components.

12. With the rear hinge frame angle (**F**) tight against the rear pit curb angle (**G**), weld the rear hinge frame angle (**F**) to the rear pit curb angle (**G**) using a 3/8 in. (9.5 mm) flare bevel skip weld — each weld being 6 in. (152 mm) long.

- Start at each end with a 6 in. (152 mm) long weld. Space all the other welds out evenly, leaving approximately 6 in. (152 mm) space between each weld.

Note: Figure 13 shows a typical weld pattern. The weld pattern will vary slightly depending on size of dock leveler.

13. Weld front of dock leveler frame (**B**) to shims located under the keepers, then weld the shims to the front pit curb steel.

14. With leveler welded into place, remove the shipping bands from around lip and leveler frame.

15. Using an external lifting device (i.e. crane or fork truck) attached to the platform lifting brackets, slowly raise the platform. Check for binding as platform is being raised.

16. If binding occurs, lower the platform. Reposition leveler and/or add or remove shims as necessary. Slowly raise platform again. If platform still binds, contact Systems, LLC Technical Services for further instructions.

WARNING

If the platform is raised using an external lifting device or the hydraulic system is opened to atmosphere, air will enter into the hydraulic system.

Whenever this happens, always cycle the leveler at least 4 times using the leveler's own hydraulic power system before allowing the leveler to be put into service. This is to make sure all air is purged from the hydraulic cylinders.

INSTALLATION

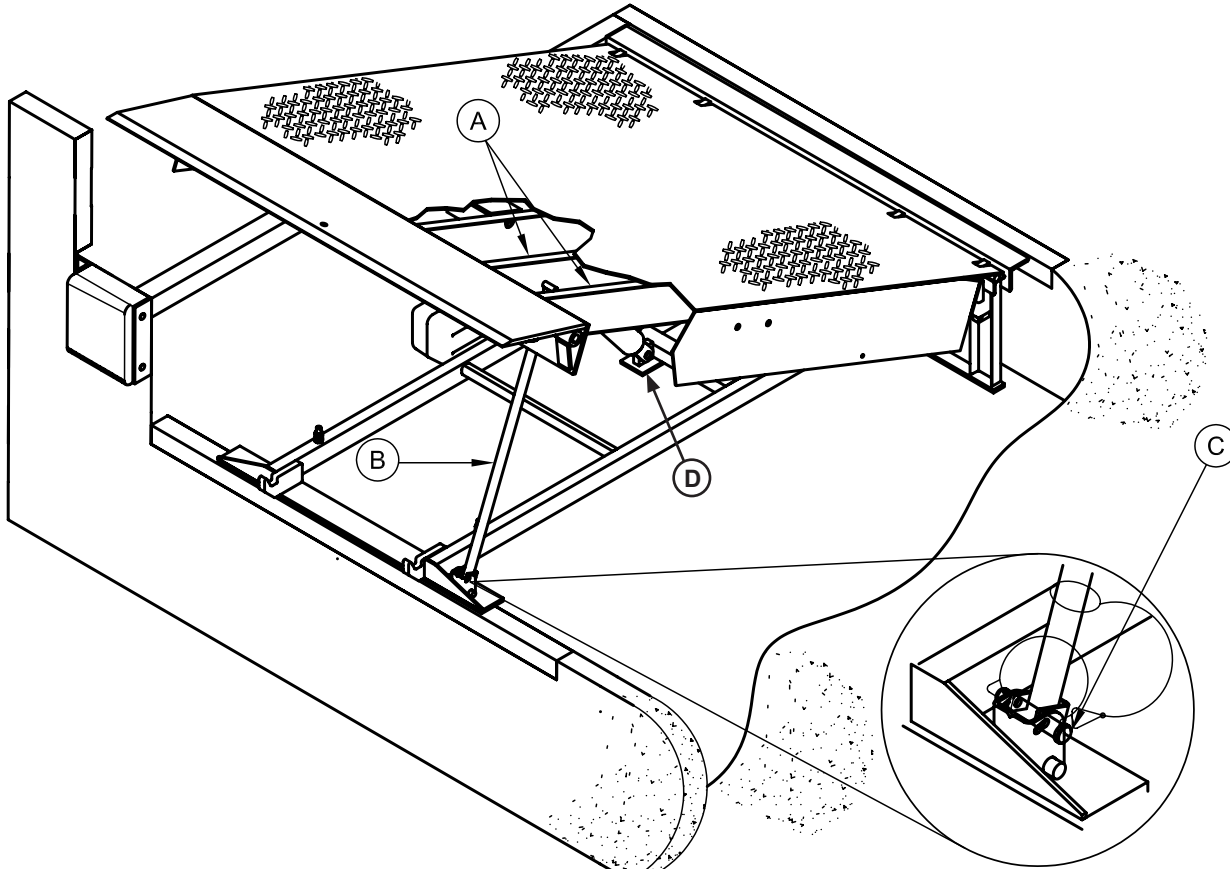

Figure 14

A— Platform Joists
B— Maintenance Prop

C— Prop Pin and Clip
D— Platform Cylinder Trunnions

17. Shim and weld the maintenance prop (Figure 14):

- a. Install shims under maintenance prop (B) where prop attaches to leveler frame (C). Make sure prop is solidly shimmed.
- b. Raise maintenance prop (B) to the service (upright) position and lock prop in this position using an OSHA approved locking device.
- c. Proceed to step 18.

18. Install shims at locations (C and D) using the pyramid or stepped shimming method (see Figure 13). Both platform cylinder trunnions must be solidly shimmed the entire length of the trunnion. Make sure the trunnions are level from side-to-side as well as from front-to-back.

19. Finish weld all shims using a fillet weld:

- Weld all shims within each shim stack to each other, then weld the shim stack to the leveler frame.
- Weld the front leveler frame shim stacks to the front pit curb steel.

WARNING

DO NOT use the maintenance prop to support the raised platform until the maintenance prop has been properly shimmed and welded. The shims must be welded to each other, and also to the leveler frame.

WARNING

Make sure the platform is properly supported in the raised position before entering the pit to finish weld the shims.

Install Dock Leveler (continued)

20. When all welding has been completed, paint all the welds and shims.
21. Install the dock bumpers as required.
22. Proceed to "Install Control Panel and Wiring" on Page 20.

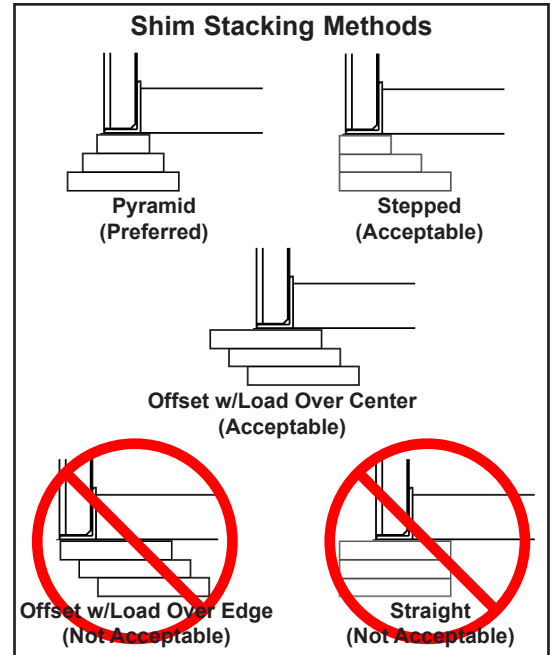

Figure 15

INSTALLATION

Install Control Panel and Wiring

DANGER

Make sure that the power source has been locked out and tagged according to OSHA regulations and approved local electrical codes.

NOTICE

DO NOT connect the dock leveler electrical wiring and ground connections until all welding has been completed.



DO NOT ground welding equipment to any hydraulic or electrical components of the dock leveler. Always ground welding equipment to the dock leveler frame, NEVER to the platform.

Failure to follow these instructions may damage the motor, hydraulics, wiring, and/or control panel.

CAUTION

All electrical work — including the installation of the disconnect panel, control panel, and final connections to the pit junction box — must be performed by a certified electrician and conform to all local and applicable national codes.

DANGER



Arc Flash and Shock Hazard
PPE [Personal Protection Equipment] Required

De-energize equipment before working on or inside. Do not open cover without appropriate PPE. Refer to NFPA 70E for PPE requirements. This panel may contain more than one power source.

Hazardous Voltage Will Result in Death or Serious Injury

1751-0736 Rev. A

NOTICE

Where indicated, all components must be connected to a SAFETY EARTH GROUND that conforms to the 1999 National Electrical Code Section 250-50 section (a) or section (c) for a grounding electrode system.

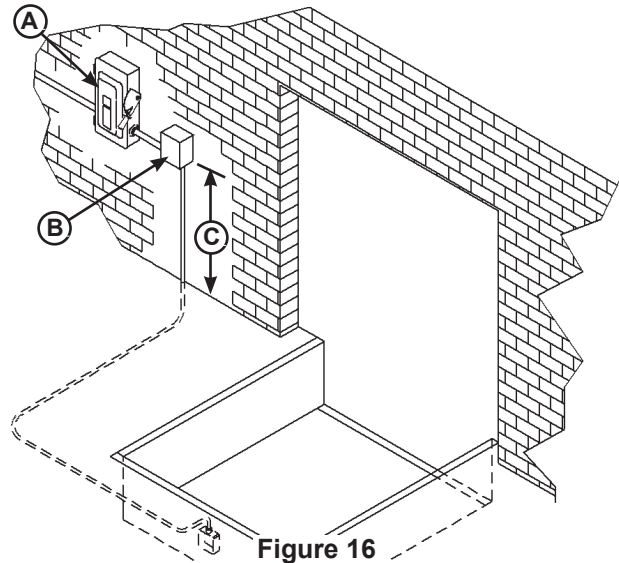
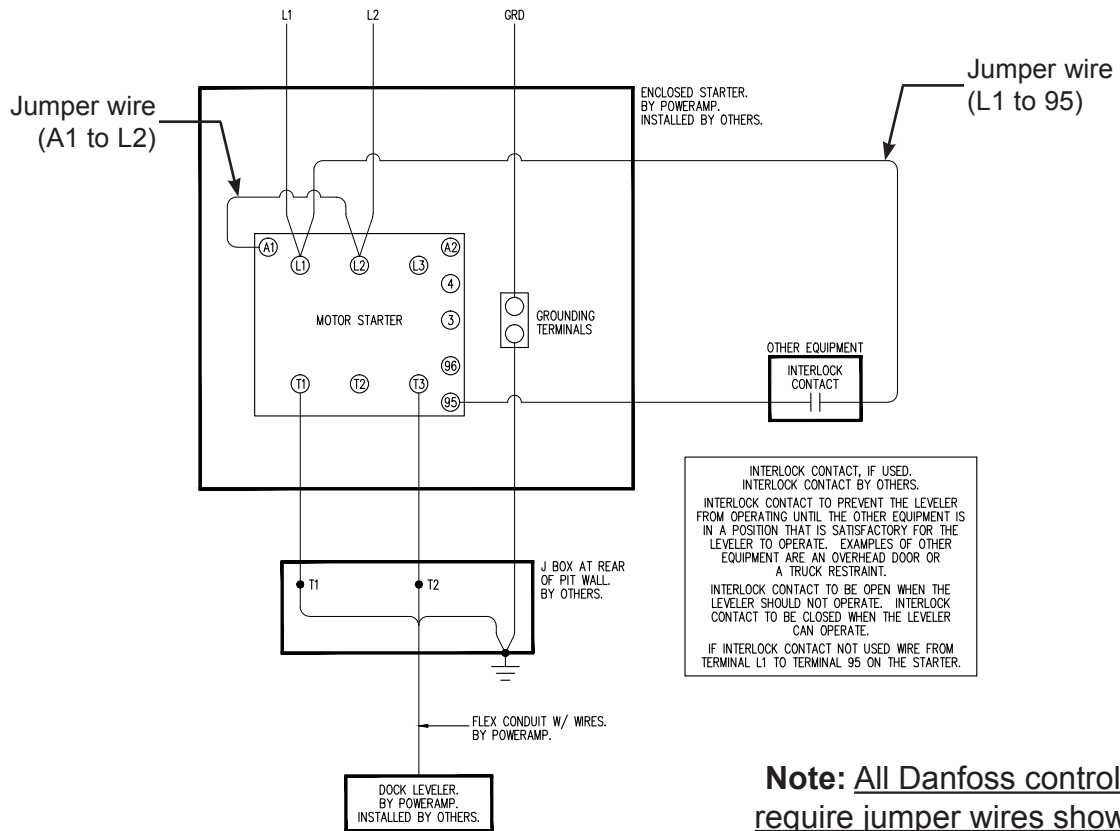

Figure 16
A— Disconnect Panel (provided by others)
B— Control Panel C— Distance, 48 in. (1219 mm)

1. Mount the push-button control panel (B) so bottom of control panel-to-dock floor distance (C) is approximately 48 in. (1219 mm). See Figure 16.
2. Install electrical disconnect panel (A) if not already installed. Disconnect panel supplied by others.
3. Install and connect the control wiring (see pages 21-24 for standard control boxes, or drawings supplied with equipment for combo boxes).
4. Connect the dock leveler power cable to the field wires in the pit junction box.
5. Seal the conduit in any location where the conduit crosses over temperature zones that could produce condensation.

Optional: Install spacers between the wall and enclosure to provide temperature insulation and air flow. If the conduit could fill with water, a drip leg may be needed.
6. Install placard (see page 25).

Danfoss Control Panel Wiring (1-Phase)



Danfoss Control Panel Wiring (3-Phase)

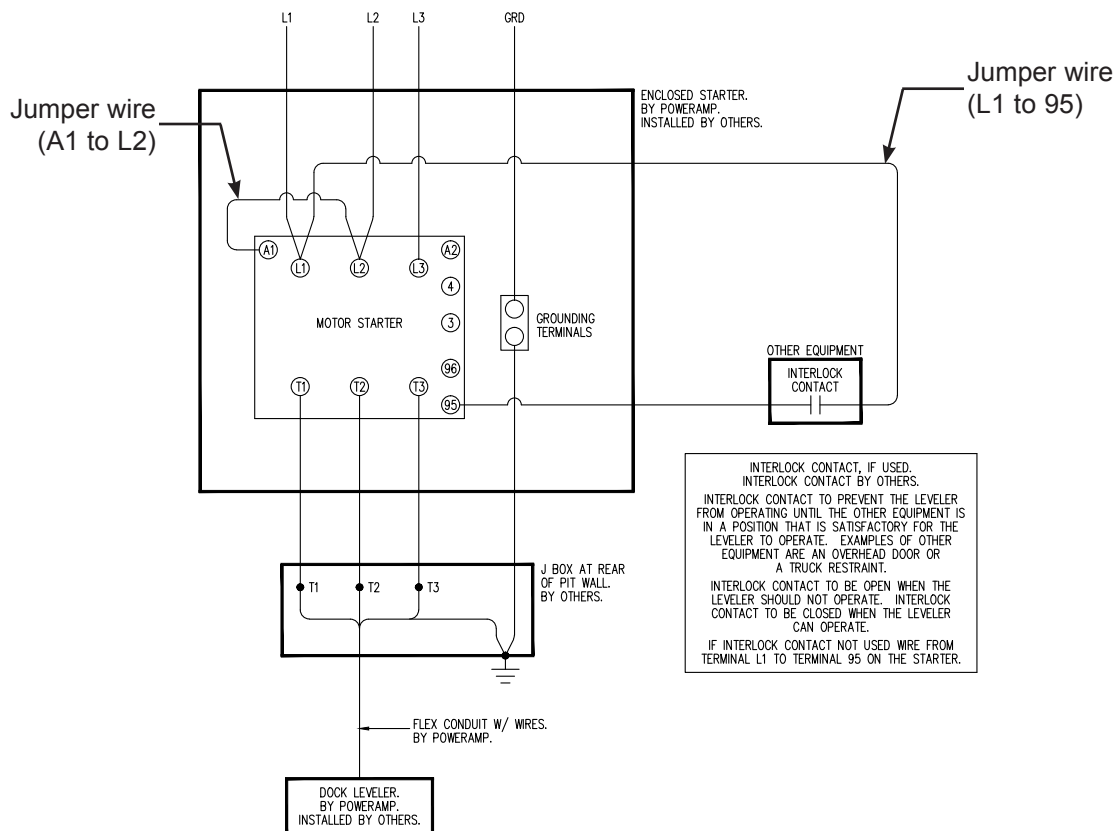

INSTALLATION

Systems, LLC Control Panel Wiring (115v 1-Phase)

CUSTOMER SUPPLIED
115 V, 1 PHASE, 60 HZ
FROM BRANCH CIRCUIT DISCONNECT SWITCH
& OVERCURRENT DEVICE BY OTHERS.
SELECT DISCONNECT SWITCH &
OVERCURRENT DEVICE PER THE NEC.
LOCATE A DISCONNECT SWITCH
NEXT TO THE CONTROL ASSY.
DUAL ELEMENT TIME DELAY FUSES
MUST BE USED FOR BRANCH
CIRCUIT PROTECTION.
SEE TABLES 1, 2 AND 3

NOTES

A. ALL FIELD WIRES & CONDUIT BY OTHERS. ALL FIELD CONNECTIONS BY OTHERS.
GROUNDING WIRE CONNECTIONS (GRD) INSIDE THE CONTROL ASSY ARE NOT SHOWN ON DRAWING BUT THESE CONNECTIONS MUST BE MADE.
B. SEE LADDER DIAGRAM 9-M0-80B-A-E FOR ELECTRICAL DATA.

TABLE 1			
RECOMMENDED FIELD WIRE SIZE			
CIRCUIT LENGTH			
50 FT	75 FT	125 FT	175 FT
10 AWG	8 AWG	6 AWG	4 AWG

TABLE 2	
TOTAL 1 PHASE FLA	
FEATURES - ONLY THOSE OPTIONS THAT AFFECT TOTAL FLA ARE LISTED	TOTAL FLA
LIP OUT &/OR E-STOP	
NO	13.9 A
YES	14.0 A

TABLE 3		
MOTOR NAMEPLATE DATA MOTOR LOCATED AT DOCK LEVELER		
VOLTAGE	FLA	HP & CODE LETTER
115 V	13.8 A	1.25 HP

FIELD WIRES:
L1, N - 115 VAC POWER
GRD - SEE NOTE A

SEE LABEL INSIDE THE CONTROL ASSY FOR OPTIONS INCLUDED ON UNIT

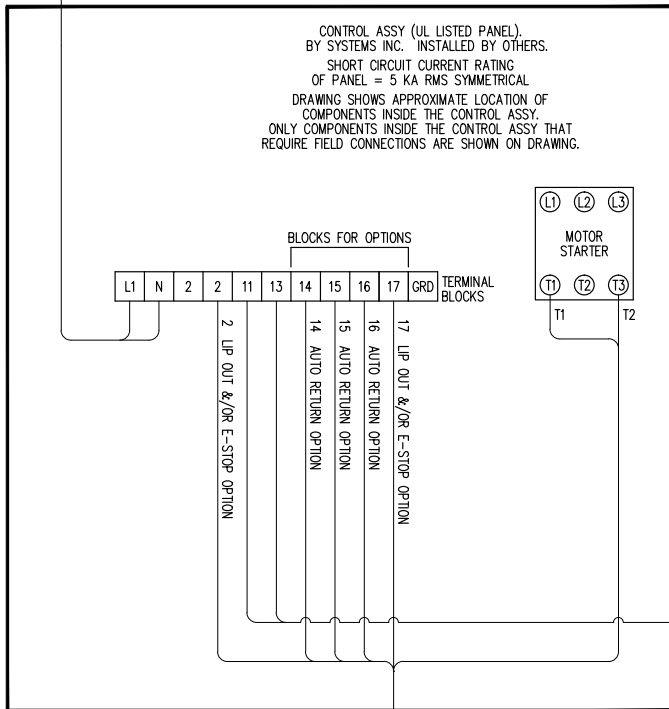

FIELD WIRES:
T1, T2 - 115 VAC MOTOR
GRD - SEE NOTE A

THE OVERHEAD DOOR CONTACT IS REMOTE & IS NOT PART OF THE UL LISTED PANEL

OVERHEAD DOOR CONTACT. BY OTHERS.
DOOR CONTACT MAY BE PROVIDED BY SYSTEMS INC IF SPECIFIED.
DOOR CONTACT TO PREVENT OPERATION OF LEVELER UNTIL DOOR FULLY RAISED. DOOR CONTACT TO BE OPEN WHEN DOOR NOT FULLY RAISED. DOOR CONTACT TO BE CLOSED WHEN DOOR FULLY RAISED. IF DOOR CONTACT USED REPLACE JUMPER AT TERMINAL BLOCKS 11 & 13 WITH DOOR CONTACT WIRES. JUMPER NOT SHOWN ON DRAWING. MINIMUM CONTACT RATING FOR DOOR CONTACT: C150 OR 2 A GEN USE @ 120 VAC. IF A PHOTO SENSOR IS USED FOR THE DOOR CONTACT SEE SYSTEMS INC TECHNICAL SERVICE BULLETIN TSB-024 FOR WIRING INSTRUCTIONS.

FIELD WIRES:
T1, T2 - 115 VAC MOTOR
14, 15, 16 AUTO RETURN OPTION - 115 VAC CONTROL
2, 17 LIP OUT &/OR E-STOP OPTION - 115 VAC CONTROL
GRD - SEE NOTE A

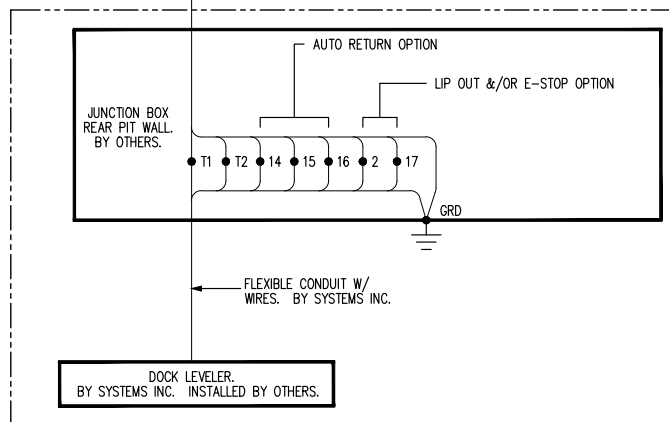

THE JUNCTION BOX AT THE REAR PIT WALL AND THE DOCK LEVELER ARE REMOTE AND ARE NOT PART OF THE UL LISTED PANEL

Systems, LLC Control Panel Wiring (208/230v 1-Phase)

CUSTOMER SUPPLIED
230/115 V, 1 PHASE, 60 HZ
FROM BRANCH CIRCUIT DISCONNECT SWITCH
& OVERCURRENT DEVICE BY OTHERS.
SELECT DISCONNECT SWITCH &
OVERCURRENT DEVICE PER THE NEC.
LOCATE A DISCONNECT SWITCH
NEXT TO THE CONTROL ASSY.
DUAL ELEMENT TIME DELAY FUSES
MUST BE USED FOR BRANCH
CIRCUIT PROTECTION.
SEE TABLES 1, 2 AND 3

NOTES
A. ALL FIELD WIRES & CONDUIT BY OTHERS. ALL FIELD CONNECTIONS BY OTHERS. GROUNDING WIRE CONNECTIONS (GRD) INSIDE THE CONTROL ASSY ARE NOT SHOWN ON DRAWING BUT THESE CONNECTIONS MUST BE MADE.
B. SEE LADDER DIAGRAM 9-M0-80B-C-E FOR ELECTRICAL DATA.

TABLE 1				
RECOMMENDED FIELD WIRE SIZE				
CIRCUIT LENGTH				
35 FT	55 FT	90 FT	140 FT	200 FT
14 AWG	12 AWG	10 AWG	8 AWG	6 AWG

TABLE 2	
TOTAL 1 PHASE FLA	
FEATURES - ONLY THOSE OPTIONS THAT AFFECT TOTAL FLA ARE LISTED	TOTAL FLA
LIP OUT &/OR E-STOP	
NO	7.0 A
YES	7.1 A

TABLE 3		
MOTOR NAMEPLATE DATA MOTOR LOCATED AT DOCK LEVELER		
VOLTAGE	FLA	HP & CODE LETTER
230 V	6.9 A	1.25 HP

FIELD WIRES:
L1, L2, N - 230/115 VAC POWER
L1-L2 = 230 VAC
L1-N = 115 VAC
GRD - SEE NOTE A

SEE LABEL INSIDE THE CONTROL ASSY FOR OPTIONS INCLUDED ON UNIT

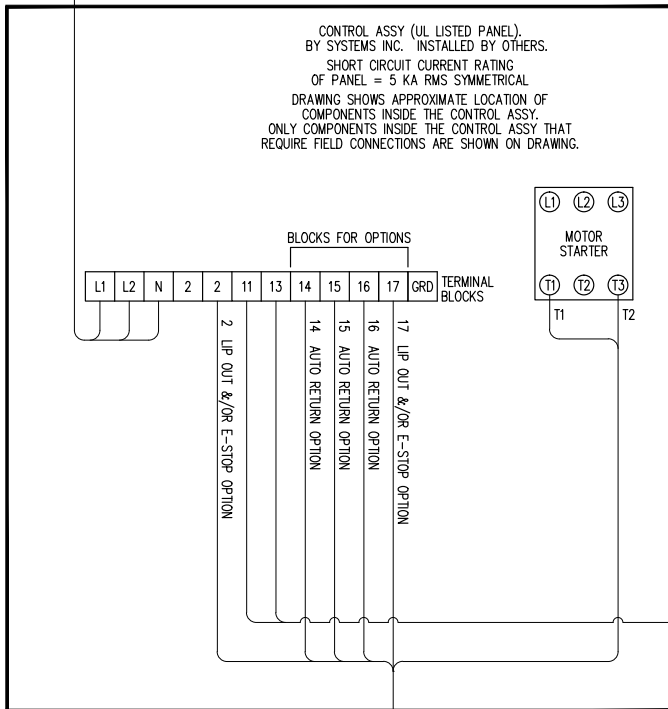

FIELD WIRES:
T1, T2 - 230 VAC MOTOR
GRD - SEE NOTE A

THE OVERHEAD DOOR CONTACT IS REMOTE & IS NOT PART OF THE UL LISTED PANEL

OVERHEAD DOOR CONTACT. BY OTHERS.
DOOR CONTACT MAY BE PROVIDED BY SYSTEMS INC IF SPECIFIED.
DOOR CONTACT TO PREVENT OPERATION OF LEVELER UNTIL DOOR FULLY RAISED. DOOR CONTACT TO BE OPEN WHEN DOOR NOT FULLY RAISED. DOOR CONTACT TO BE CLOSED WHEN DOOR FULLY RAISED. IF DOOR CONTACT USED REPLACE JUMPER AT TERMINAL BLOCKS 11 & 13 WITH DOOR CONTACT WIRES. JUMPER NOT SHOWN ON DRAWING. MINIMUM CONTACT RATING FOR DOOR CONTACT: C150 OR 2 A GEN USE @ 120 VAC. IF A PHOTO SENSOR IS USED FOR THE DOOR CONTACT SEE SYSTEMS INC TECHNICAL SERVICE BULLETIN TSB-024 FOR WIRING INSTRUCTIONS.

FIELD WIRES:
T1, T2 - 230 VAC MOTOR
14, 15, 16 AUTO RETURN OPTION - 115 VAC CONTROL
2, 17 LIP OUT &/OR E-STOP OPTION - 115 VAC CONTROL
GRD - SEE NOTE A

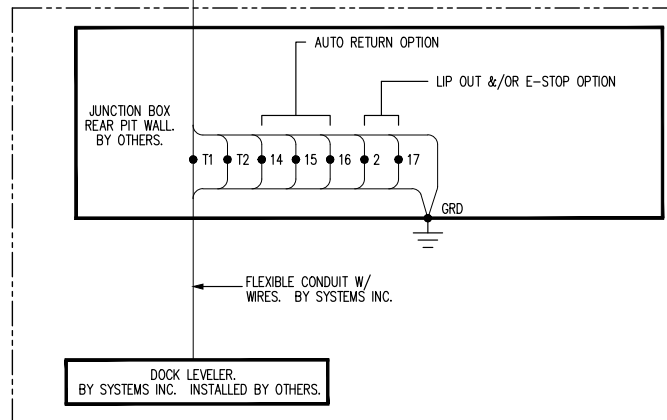

THE JUNCTION BOX AT THE REAR PIT WALL AND THE DOCK LEVELER ARE REMOTE AND ARE NOT PART OF THE UL LISTED PANEL

INSTALLATION

Systems, LLC Control Panel Wiring (3-Phase)

CUSTOMER SUPPLIED
208/230/460/575 V, 3 PHASE, 60 HZ
FROM BRANCH CIRCUIT DISCONNECT SWITCH
& OVERCURRENT DEVICE BY OTHERS.
SELECT DISCONNECT SWITCH &
OVERCURRENT DEVICE PER THE NEC.
LOCATE A DISCONNECT SWITCH
NEXT TO THE CONTROL ASSY.
DUAL ELEMENT TIME DELAY FUSES
MUST BE USED FOR BRANCH
CIRCUIT PROTECTION.
SEE TABLES 1, 2 AND 3

NOTES

A. ALL FIELD WIRES & CONDUIT BY OTHERS. ALL FIELD CONNECTIONS BY OTHERS.
GROUNDING WIRE CONNECTIONS (GRD) INSIDE THE CONTROL ASSY ARE NOT SHOWN ON DRAWING BUT THESE CONNECTIONS MUST BE MADE.
B. SEE LADDER DIAGRAM 9-M0-80B-L-E FOR ELECTRICAL DATA.

CIRCUIT LENGTH	
130 FT	200 FT
14 AWG	10 AWG

3 PHASE VOLTAGE	TOTAL FLA
208 V	3.9 A
230 V	4.0 A
460 V	2.0 A
575 V	2.2 A

3 PHASE VOLTAGE	FLA	HP
208 V	3.7 A	1.25 HP
230 V	3.8 A	
460 V	1.9 A	1.5 HP
575 V	2.1 A	

FIELD WIRES:
L1, L2, L3 - 208/230/460/575 VAC POWER
GRD - SEE NOTE A

SEE LABEL INSIDE THE CONTROL ASSY FOR OPTIONS INCLUDED ON UNIT

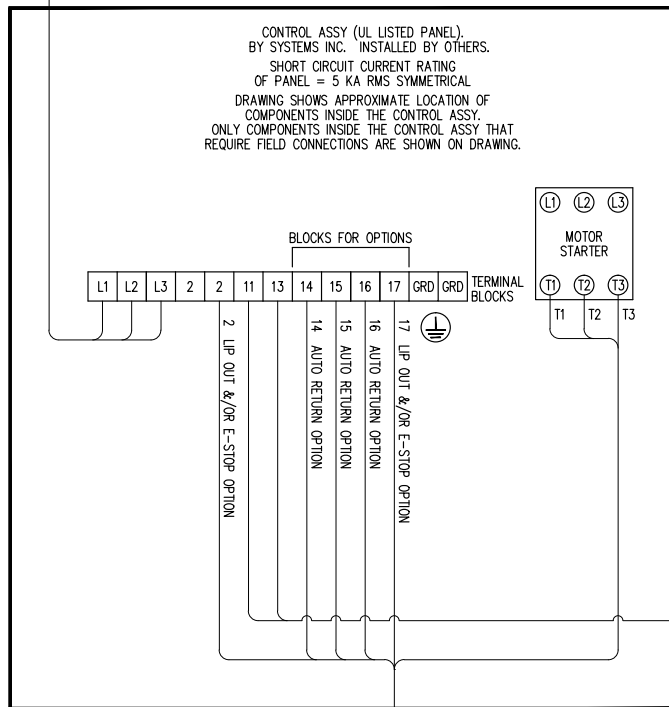

FIELD WIRES:
11, 13 - 115 VAC CONTROL
GRD - SEE NOTE A

THE OVERHEAD DOOR CONTACT IS REMOTE & IS NOT PART OF THE UL LISTED PANEL

OVERHEAD DOOR CONTACT. BY OTHERS.
DOOR CONTACT MAY BE PROVIDED BY SYSTEMS INC IF SPECIFIED.
DOOR CONTACT TO PREVENT OPERATION OF LEVELER UNTIL DOOR FULLY RAISED. DOOR CONTACT TO BE OPEN WHEN DOOR NOT FULLY RAISED.
DOOR CONTACT TO BE CLOSED WHEN DOOR FULLY RAISED. IF DOOR CONTACT USED REPLACE JUMPER AT TERMINAL BLOCKS 11 & 13 WITH DOOR CONTACT WIRES. JUMPER NOT SHOWN ON DRAWING. MINIMUM CONTACT RATING FOR DOOR CONTACT: C150 OR 2 A GEN USE @ 120 VAC. IF A PHOTO SENSOR IS USED FOR THE DOOR CONTACT SEE SYSTEMS INC TECHNICAL SERVICE BULLETIN TSB-024 FOR WIRING INSTRUCTIONS.

FIELD WIRES:
T1, T2, T3 - 208/230/460/575 VAC MOTOR
14, 15, 16 AUTO RETURN OPTION - 115 VAC CONTROL
2, 17 LIP OUT &/OR E-STOP OPTION - 115 VAC CONTROL
GRD - SEE NOTE A

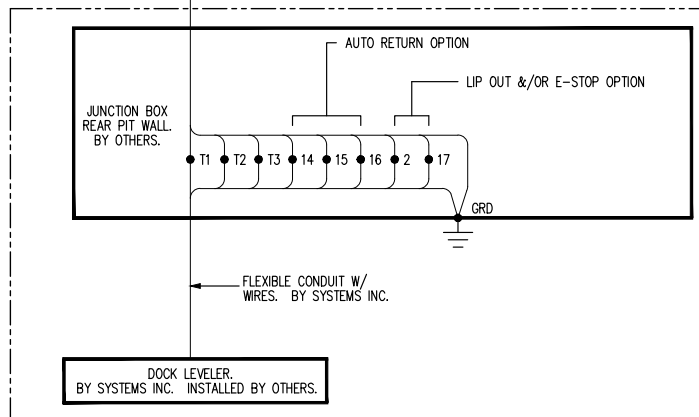

THE JUNCTION BOX AT THE REAR PIT WALL AND THE DOCK LEVELER ARE REMOTE AND ARE NOT PART OF THE UL LISTED PANEL

Placard Installation Instructions

- Owner/Users are responsible for the installation and placement of product placards.
- Make sure placard is in plain view of dock leveler and/or vehicle restraint operations.
- Suggested placement of placard is near control box attached to electrical conduit by using nylon cable tie. If there is no control box present, mount placard on wall to the immediate left of leveler at eye level.

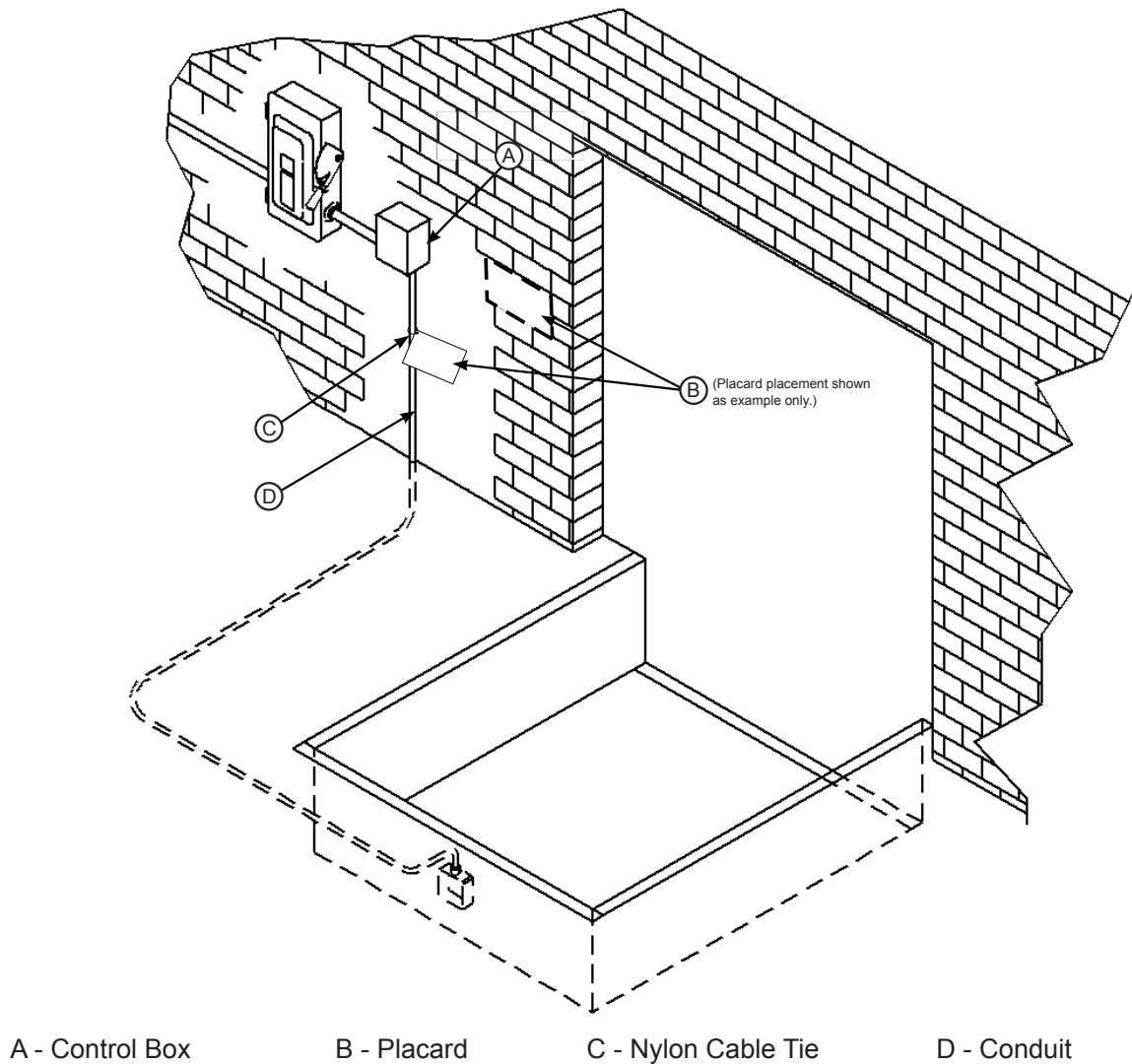

Figure 17

INSTALLATION

Put New Dock Leveler Into Service

WARNING

A hard hat or other applicable head protection should always be worn when working under or around a dock leveler.

Always stand clear of platform lip when working in front of the dock leveler.

1. Disconnect the external lifting device and chains from the lifting brackets.

2. Check that the leveler is flush with the dock floor and that the platform lip contacts both lip keepers evenly.

Note: If an excessive transition exists between the dock floor and leveler and/or lip does not contact both lip keepers evenly, contact Systems, LLC Technical Services for further instructions.

3. Turn the main electrical power ON.

4. Raise the leveler platform fully by pressing and holding the RAISE button.

Note: The platform of a properly operating dock leveler will automatically stop rising when it reaches its maximum full raised height, at which point, the lip extends. When the lip is fully extended, the powerpack will go into pressure relief. (If the lip does not extend correctly, see Troubleshooting section.)

5. Release the RAISE button to lower the platform. As long as there is no vehicle present at the dock, the platform will lower to the full below-dock position as the lip folds.

Note: If a transport vehicle is present, the platform will lower until the lip rests on the transport vehicle's bed.

6. When the platform lowers to the full below-dock position, press and hold the RAISE button until the platform rises just enough to clear the lip keepers, then release the RAISE button to allow the platform to lower to the cross-traffic (stored) position (lip engages lip keepers).

Note: For dock levelers equipped with the Auto Return To Dock (ARTD), the platform will automatically return to the cross-traffic position if the ARTD is enabled. When the platform is at the full below-dock position, there is a six-second delay before the platform will automatically rise to the cross-traffic position.

7. Perform steps 4-6 at least four times to purge any air that may be in the hydraulic system and to ensure proper operation.

8. Raise the platform fully. Hold the platform at this position using the RAISE button and move the maintenance prop to the service (upright) position. Release the RAISE button to allow the platform to lower until it is resting on the maintenance prop.

DANGER

Unless the dock leveler is equipped with a tethered remote, two people are required to engage the maintenance prop: one person to operate the unit, the other person to engage the maintenance prop.

In addition, it is recommended and good safety practice to use an additional means to support the dock platform and lip anytime when physically working in front of or under the dock leveler. This additional means may include, but is not limited to a boom truck, fork truck, stabilizing bar or equivalent.

9. Secure the maintenance prop with the maintenance prop lock-out.

10. With the maintenance prop supporting the platform, remove the lifting brackets.

11. Release the maintenance prop by unlocking the lock-out.

12. Press and hold the RAISE button until the maintenance prop drops to its stored position. Release the RAISE button and allow the platform to lower fully.

Operational Precautions

DANGER

Stay clear of dock leveler and vehicle restraint when transport vehicle is entering or leaving dock area.

DO NOT move or use the dock leveler or restraint if anyone is under or in front of leveler.

Keep hands and feet clear of pinch points. Avoid putting any part of your body near moving parts.

WARNING

Only trained personnel should operate the dock leveler.

DO NOT use a broken or damaged dock leveler. Make sure proper service and maintenance procedures have been performed on leveler before using.

Transport vehicle wheels must be chocked unless a vehicle restraint is used. Never remove the wheel chocks until loading/unloading is finished and transport driver has been given permission to leave.

Make sure platform lip rests on the transport vehicles bed with at least 4 in. (102 mm) of overlap.

Maintain a safe distance from side edges of leveler during the loading/unloading process.

WARNING

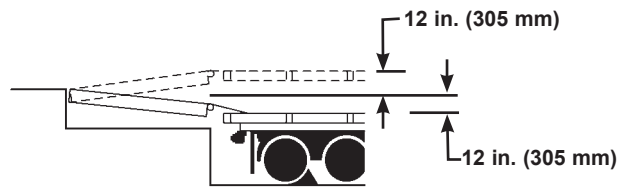

The HP/H hydraulic dock leveler is designed to compensate for a maximum ± 12 in.* (305 mm) of height difference between the loading dock and the transport vehicle bed. DO NOT use the dock leveler if the transport vehicle bed is more than 12 in. (305 mm) higher or lower than the dock floor.

*Service height may vary with design specifications.

DO NOT overload the dock leveler.

DO NOT operate any equipment while under the influence of alcohol or drugs.

DO NOT leave equipment or material unattended on the dock leveler.

OPERATION

Operating Instructions

Ramp Loading/Unloading

1. Before activating dock leveler, check to make sure the transport vehicle is positioned squarely against dock bumpers. Ensure lip will avoid contact with transport vehicle frame, sides and cargo during dock leveler activation. If contact is likely or observed, reposition transport vehicle.

2. Instruct driver to remain at the dock until the loading or unloading process has been completed.

3. Chock the transport vehicle wheels, or use a vehicle restraint if available.

4. Extend the dock leveler onto the transport vehicle as follows:

- a. Raise the platform by pressing and holding the RAISE button.
- b. Hold the RAISE button until the lip is fully extended, then release the RAISE button. The platform will lower until the lip is resting on the transport vehicle bed.
- c. Make sure that the lip is fully extended and supported on the transport vehicle along the entire width of the platform, with at least 4 in. (102 mm) of lip contacting the transport vehicle bed. See Figure 18.

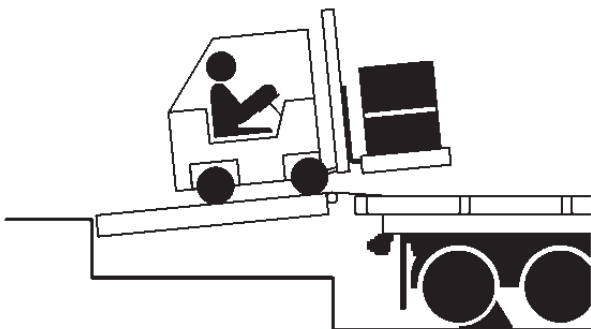

Figure 18

5. Proceed with loading or unloading the transport vehicle.

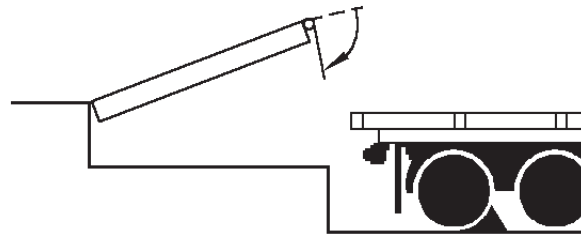

Figure 19

6. When loading or unloading is finished, raise the platform by pressing and holding the RAISE button until the lip folds enough to land in the lip keepers, then release the RAISE button. The platform will return to the cross-traffic position. See Figure 19.

7. Remove chocks from transport vehicle wheels, or release the vehicle restraint if used.

8. Indicate to driver that the transport vehicle may leave the dock.

Operating Instructions (continued)

End Loading/Unloading

1. Before activating dock leveler, check to make sure the transport vehicle is positioned squarely against dock bumpers. Ensure lip will avoid contact with transport vehicle frame, sides and cargo during dock leveler activation. If contact is likely or observed, reposition transport vehicle.

2. Instruct driver to remain at the dock until the loading or unloading process has been completed.

3. Chock the transport vehicle wheels, or use a vehicle restraint if available.

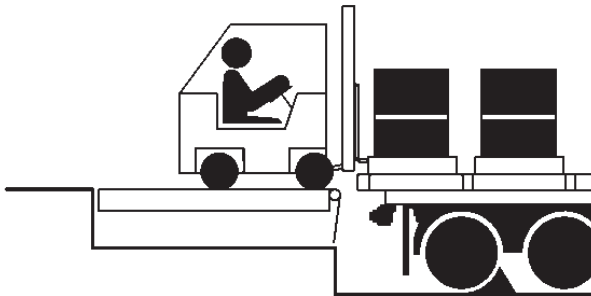

Figure 20

4. If transport vehicle bed is at or above dock floor level, leave leveler at the cross-traffic position and proceed with loading or unloading (see Figure 20). If transport vehicle bed is below the dock floor level, continue with Step 5.

5. Raise the platform by pressing and holding the RAISE button until the lip extends just enough to clear the lip keepers, then release the RAISE button.

6. Allow the platform to drift down to the full below-dock position.



Figure 21

7. Proceed with loading or unloading (see Figure 21).

Note: When end unloading is finished and access to the rest of the transport vehicles is still required, the platform lip will need to be extended. See Ramp Loading/Unloading Instructions on page 26 for further instructions.

8. When end loading or unloading is finished, raise the platform by pressing and holding the RAISE button until the lip folds enough to land in the lip keepers, then release the RAISE button. The platform will return to the cross-traffic position.

9. Remove chocks from transport vehicle wheels, or release the vehicle restraint if used.

10. Indicate to driver that the transport vehicle may leave the dock.

OPERATION

Optional Equipment

Quick Cycle Lip Extend (Lip Out)

Note: For dock levelers equipped with optional Quick Cycle Lip Extend/Lip Out, the dock leveler lip can be extended independently of the leveler platform with the following sequence:

1. Complete steps 1-4 in “Operating Instructions” on page 28.
2. When leveler has risen enough for lip to clear the transport vehicle bed, press and hold the LIP button in addition to the RAISE button. Leveler will stop raising and lip will extend.
3. When lip has fully extended, release RAISE and LIP buttons. Leveler will fall into transport vehicle with lip fully extended.
4. Continue with step 5 in “Operating Instructions.”

Emergency Stop (E-Stop)

Note: For dock levelers equipped with optional Emergency Stop (E-Stop), dock leveler can be halted in place by using the Emergency Stop button:

1. While operating any function of the dock leveler, press the Emergency Stop button (E).
2. Equipment being operated will halt in place.
3. When hazard has been cleared or system must be operated, pull the Emergency Stop button outward.

WARNING

When Emergency Stop is active, DO NOT go under the dock leveler, walk or drive on the dock leveler, or leave forklift and/or material sitting on the leveler!

If Emergency Stop button is pressed with the dock leveler unsupported in the working zone, the leveler will descend when E-Stop is released!

Always make sure the platform is properly supported in the raised position before entering the pit or going under the dock leveler.

4. Continue operating dock equipment as needed.

Auto Return To Dock (ARTD)

Note: For dock levelers equipped with optional Auto Return To Dock (ARTD), the dock leveler can self-store if a transport vehicle departs the loading dock before the platform is stored.

To enable Auto Return To Dock, turn the ARTD switch to the ON position. If end loading or unloading is required, turn the ARTD switch to the OFF position and follow the steps on page 29. When end loading or unloading is complete, turn the ARTD switch back to the ON position, and the dock leveler will self-store.

CAUTION

Whenever end loading or unloading with the platform in the below-dock position, make sure the ARTD switch is in the OFF position. DO NOT turn the ARTD switch to the ON position until end loading or unloading is finished.

Maintenance Precautions

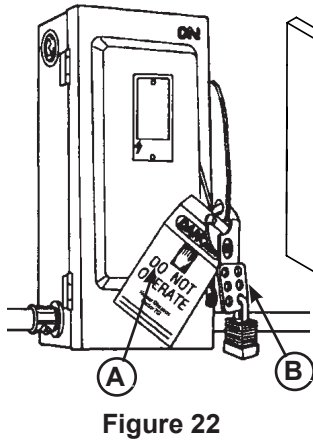

Figure 22

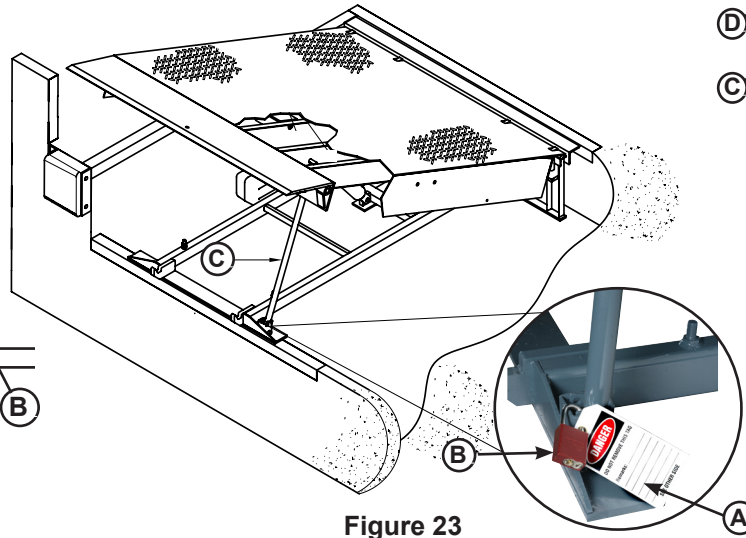

Figure 23

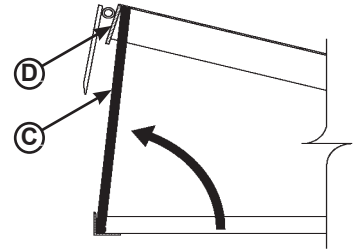

Figure 24

A— Tag Out Device B—Lock Out Device C— Maintenance Prop D— Header

! DANGER

Unless the dock leveler is equipped with a tethered remote, two people are required to engage the maintenance prop: one person to operate the unit, the other person to engage the maintenance prop.

In addition, it is recommended and good safety practice to use an additional means to support the dock platform and lip anytime when physically working in front of or under the dock leveler. This additional means may include, but is not limited to a boom truck, fork truck, stabilizing bar or equivalent.

When working with electrical or electronic controls, make sure that the power source has been tagged (A) and locked out (B) according to OSHA regulations and approved local electrical codes (see Figure 22).

Whenever maintenance is to be performed under the dock leveler platform, support the platform with maintenance prop (C). Position the maintenance prop behind front header plate (D) while staying clear of the lip. The lip will fold down after the platform has rested on the maintenance prop. Lock the maintenance prop in the service (upright) position using an OSHA approved lockout device* (B) and tag out device* (A). See Figures 23 and 24.

! WARNING

Always post safety warnings and barricade the work area at dock level and ground level to prevent unauthorized use of the unit before maintenance is complete.

Only the person servicing the equipment should have the capability to remove the lockout devices. The tag out devices* must inform that repairs are in process and clearly state who is responsible for the lockout condition.

! WARNING

A hard hat or other applicable head protection should always be worn when working under or around a dock leveler.

Always stand clear of platform lip when working in front of the dock leveler.

* Refer to OSHA regulations 1910.146. Confined Space and 1910.147. Lockout/Tagout

MAINTENANCE

Periodic Maintenance

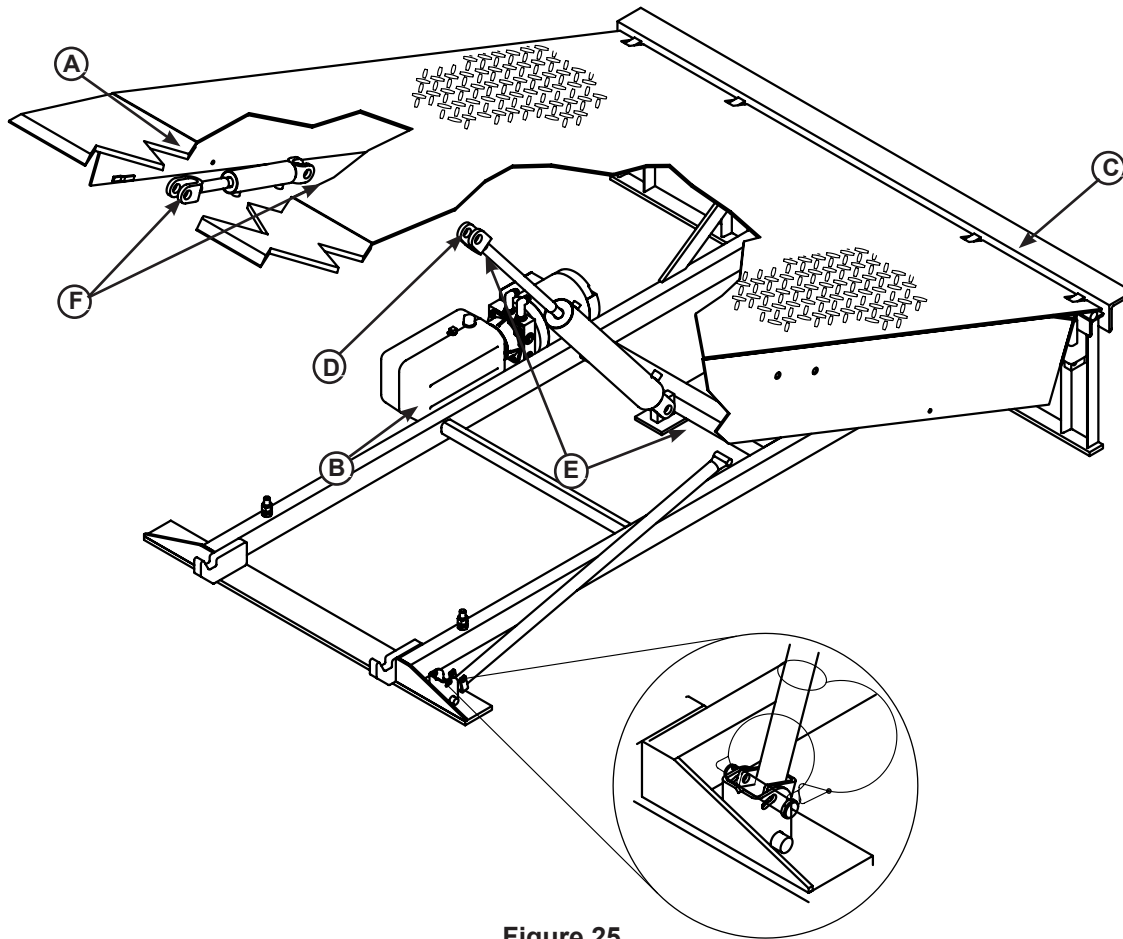

Figure 25

A— Lip Hinge Area
B— Power Unit and Reservoir

C— Platform Hinge Area
D— Platform Cylinder Trunnion

E— Platform Cylinder Pins
F— Lip Cylinder Pins

To ensure normal operation of the dock leveler, use only aircraft hydraulic fluid designed to meet or exceed military specification MIL-H-5606-G. It is recommended that the following hydraulic fluids be used:

- ULTRA-VIS-HVI-15
- Aero Shell Fluid 4 or Fluid 41
- Mobil Aero HFA Mil-H5606A or Aero HF
- Texaco Aircraft Hydraulic Oil 15 or 5606
- Exxon Univis J13
- Castrol Brayco Micronic 756

These fluid brands can be mixed together. Use of hydraulic fluids with equivalent specifications to those listed here are acceptable.

NOTICE

Use of fluids that do not have equivalent specifications to those in the preceding list will result in abnormal operation of the dock leveler and voiding of warranty.

Weekly Maintenance

- Operate the dock leveler through the complete operating cycle to maintain lubrication.

Note: To thoroughly inspect the platform hinge area, put the platform in the full below-dock position.

- Inspect the platform hinge and the lip hinge areas. The hinge areas must be kept free of dirt and debris. Build-up of foreign material in the hinge areas will cause abnormal operation.
- Inspect warning decals and placards. Replace if damaged or missing.

Quarterly Maintenance

- Complete Weekly Maintenance.
- Inspect the following for damage/abnormal wear:
 - Check welds for cracks.
 - Cylinder pins and mounting holes.
 - Lip hinge pins and rear hinge pins.
 - Check toe guards for free movement.
 - Check J-box for water damage.
 - Inspect hoses, cylinders, fittings and powerpack.
 - Control box and conduit for damage.
 - Bumpers for more than 1" of wear. Replace worn, loose, damaged or missing bumpers.
 - Side and rear weather seals.
- Lubricate the following areas with light weight machine oil (see Figure 25):
 - (A) — Lip hinge area unless equipped with grease fittings (apply oil to the top of the entire length of lip hinge when platform is at the full below-dock position and lip is folded)
 - (C) — Platform hinge area (apply oil to top of all platform hinges when platform is at the full below-dock position)
 - (E) — Platform cylinder-to-platform frame pin
 - (F) — Lip cylinder-to-platform frame pin

Note: Apply grease to lip hinge grease fittings if equipped.

NOTICE

Failure to properly lubricate the dock leveler will cause abnormal operation of the leveler.

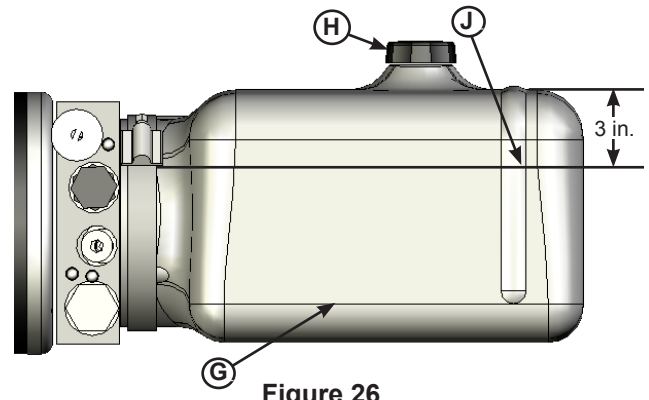

Figure 26

G - Reservoir

J - Fluid Level

H - Breather Cap

- Check reservoir fluid level (J, see Figure 26):
 1. Raise the platform fully and engage the maintenance prop in the service position.
 2. Turn OFF all electrical power to the leveler.
 3. Remove breather cap (H).
 4. Measure fluid level. The fluid level should be approximately 3 in. (76.5 mm) from top of reservoir (G) with platform at the below-dock position.
 5. Add hydraulic fluid if necessary. Use only recommended fluid (see page 32).
 6. Install breather cap.
 7. Turn ON electrical power to the leveler.
 8. Return the platform to the cross-traffic position.

Yearly Maintenance

- Complete Quarterly Maintenance.
- Change hydraulic oil (may be required more often depending upon conditions).

ADJUSTMENTS

Adjust Hydraulic Pump

! DANGER

Unless the dock leveler is equipped with a tethered remote, two people are required to engage the maintenance prop: one person to operate the unit, the other person to engage the maintenance prop.

In addition, it is recommended and good safety practice to use an additional means to support the dock platform and lip anytime when physically working in front of or under the dock leveler. This additional means may include, but is not limited to a boom truck, fork truck, stabilizing bar or equivalent.

! WARNING

When service under the dock leveler is required, always lock all electrical disconnects in the OFF position after raising the platform and engaging the maintenance prop.

Always post safety warnings and barricade the work area at dock level and ground level to prevent unauthorized use of the dock leveler before maintenance is complete.

A hard hat or other applicable head protection should always be worn when working under or around a dock leveler.

Always stand clear of platform lip when working in front of the dock leveler.

Main Pressure Relief Adjustment

Note: The main pressure relief may need to be *increased* if the platform does not rise or rises slowly and the system operates in pressure relief mode.

The main pressure relief may need to be *decreased* if the pump motor loads down when platform reaches the full raised position.

See Troubleshooting section on pages 38-41 for more information.

1. Raise the platform fully and engage the maintenance prop in the service position.
2. Turn OFF all electrical power to the dock leveler.

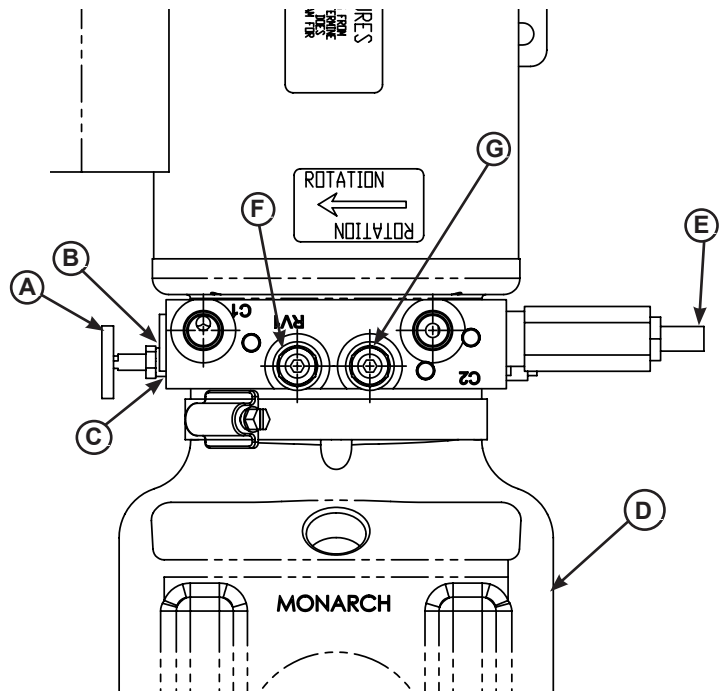

Figure 27

- | | |
|--|---------------------------------|
| A— Shuttle Valve, Ramp Speed, Lowering | D—Reservoir |
| B— Lip Check Relief | E—Sequence Valve, Lip Extension |
| C—System P.O. Check | F—Main System Relief Valve |
| | G—Lip Float Valve |

3. Attach lock out/tag out devices.
4. Loosen jam nut on valve (F)
5. Adjust hex adjusting screw (F) in small 1/4 turn increments as follows:
 - To increase pressure relief, turn hex screw clockwise.
 - To decrease pressure relief, turn hex screw counterclockwise.
6. Tighten the jam nut.
7. Turn ON electrical power to the dock leveler.
8. Remove lock out/tag out devices.
9. Disengage the maintenance prop.
10. Cycle leveler and verify pressure relief setting.
11. Repeat steps 1– 10 as necessary.

Adjust Hydraulic Pump (continued)

Lowering Speed, Sequence Valve and Lip Float Adjustments

1. RAMP LOWERING SPEED, CONTROLS RAMPS DOWNWARD MOTION IN TIME.
 - A. IF PLATFORM IS LOWERING TOO SLOW, TURN ADJUSTMENT COUNTER-CLOCKWISE TO INCREASE ITS RATE OF DESCENT.
 - B. IF PLATFORM IS LOWERING TOO FAST, TURN ADJUSTMENT CLOCKWISE TO DECREASE ITS RATE OF DESCENT.
2. SEQUENCE VALVE CONTROLS LIP EXTENSION TIMING ONCE RAMP HAS EXTENDED.
 - A. IF LIP EXTENDS BEFORE RAMP IS AT FULL RAISED POSITION TURN ADJUSTMENT CLOCKWISE TO DELAY THE LIP EXTENSION.
 - B. IF LIP EXTENDS SLOWLY OR DELAYED AFTER THE RAMP IS AT FULL RAISED POSITION, TURN ADJUSTMENT COUNTER-CLOCKWISE TO EXTEND THE LIP SOONER.
3. LIP FLOAT ADJUSTMENT CONTROLS THE POWERED IN LIP FEATURE
 - A. IF LIP DOES NOT COME FULLY PENDANT AS UNIT IS BEING STORED TURN ADJUSTMENT COUNTER-CLOCKWISE 1/4 TURN AT A TIME.
 - B. IF LIP DRAGS HEAVILY ON THE TRAILER OR LIP KEEPERS WHEN UNIT IS BEING STORED, TURN ADJUSTMENT CLOCKWISE 1/4 TURN AT A TIME.

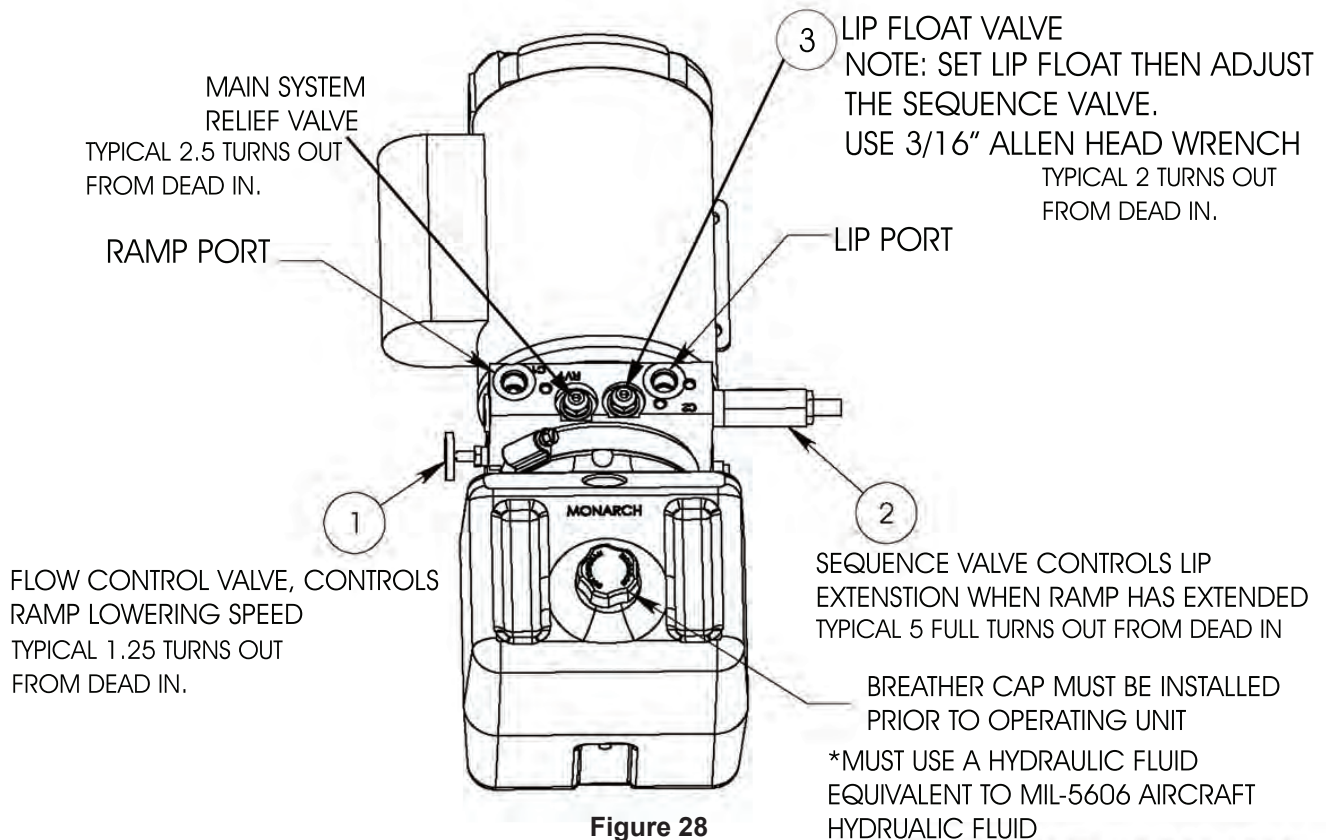

Figure 28

Tank Capacity:

25K-75K Levelers (single hoist cylinders)	4 quarts
100K+ Levelers (dual hoist cylinders).....	5 quarts

ADJUSTMENTS

Adjust Auto Return To Dock (ARTD)

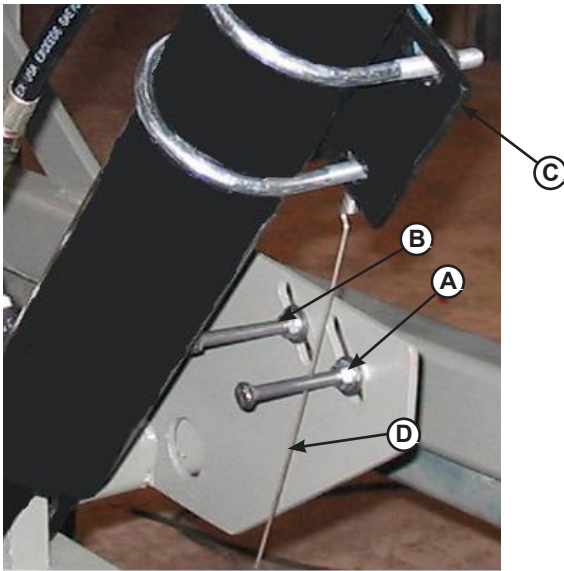

Figure 29

A— ARTD Activation Bolt C— ARTD Limit Switch
B— ARTD De-Activation Bolt D— ARTD Switch Arm

Auto Return To Dock (ARTD)

HP/H levelers can be equipped with optional Auto Return To Dock (ARTD) if leveler is not interlocked with a transport vehicle restraint.

The ARTD allows the platform to automatically return to the cross-traffic (stored) position after the transport vehicle departs.

Adjust Auto Return To Dock (ARTD)

1. Raise platform fully and engage the maintenance prop in the service position. Allow platform to rest on the prop so the lip will fully fold until it contacts the lip stops.
2. Turn OFF all electrical power to the leveler and lock out/tag out the electrical power supply.
3. Loosen nuts (**A**). Slide bolt up to engage ARTD higher below dock or slide down to engage ARTD lower below dock. Tighten nuts.
4. Turn power back on and run the unit through a full cycle and repeat if necessary.
5. Loosen nut (**B**) and slide bolt up to shut ARTD higher above dock or slide the bolt down to shut off the ARTD less above dock.



CAUTION

When servicing transport vehicles that are lower than dock height, it is recommended that the Below Dock End Load Switch (**F**) is switched to BELOW DOCK mode AFTER the lip is in the bed of the transport vehicle to prevent the Auto Return feature from activating inadvertently.

Adjust Auto Return To Dock (ARTD, continued)

Full Below Dock Position

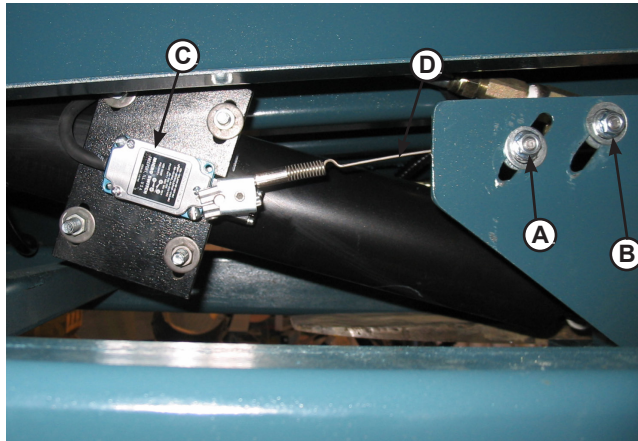

Figure 30

A— ARTD Activation Bolt C— ARTD Limit Switch
B— ARTD De-Activation Bolt D— ARTD Switch Arm

In the full below dock position, the switch arm (D) will be activated by the front bolt (A) and trapped under the back bolt (B). The switch will activate approximately 1 inch before the front header is fully below dock.

As the platform self-stores, the lip will pull in first and then the platform will start to raise. Once the platform is high enough for the lip clear the lip keepers, the back bolt (B) will de-activate the switch and turn off the pump, and the platform will descend to rest in the lip keepers in the cross traffic position.

NOTICE

The unit must raise enough to allow the lip to fully retract to have the lip rest in to the lip keepers.

The ARTD Switch arm (D) must be between both (A) and (B) to work properly.

Below Dock End Load Switch

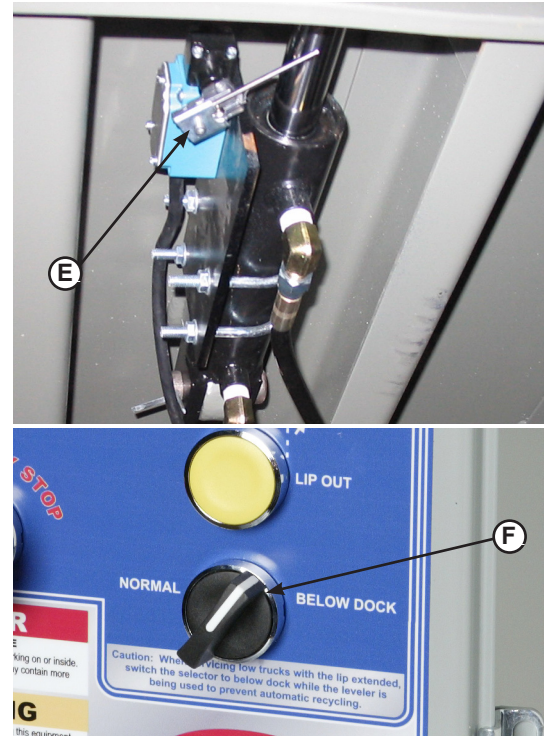

Figure 31

E— Below Dock End Load Switch F— Selector Switch

The Below Dock End Load Switch (E) controls the lip when end loading below dock. To activate, turn the selector switch (F) to BELOW DOCK position.

This will DE-ACTIVATE the Auto Return To Dock feature.

Press and hold the RAISE button until the platform is fully open. The lip will extend until the switch contact is opened and stops the pump.

Note: When set correctly, the lip will extend only 2-3 inches to stay within the bumper spacing.

The platform will float to the full below dock position and the transport vehicle and be loaded/unloaded.

When complete, turn the Below Dock End Load Switch (F) back to the NORMAL position; the platform will self-store to the cross traffic position.

TROUBLESHOOTING

DANGER

Unless the dock leveler is equipped with a tethered remote, two people are required to engage the maintenance prop: one person to operate the unit, the other person to engage the maintenance prop.

In addition, it is recommended and good safety practice to use an additional means to support the dock platform and lip anytime when physically working in front of or under the dock leveler. This additional means may include, but is not limited to a boom truck, fork truck, stabilizing bar or equivalent.

WARNING

When service under the dock leveler is required, always lock all electrical disconnects in the OFF position after raising the platform and engaging the maintenance prop.

Always post safety warnings and barricade the work area at dock level and ground level to prevent unauthorized use of the dock leveler before maintenance is complete.

A hard hat or other applicable head protection should always be worn when working under or around a dock leveler.

Always stand clear of platform lip when working in front of the dock leveler.

Before performing the detailed troubleshooting procedures, check the following items first:

- Check all fuses inside the control panel(s). Replace any blown fuse(s) with a fuse of equal specification.
- Make sure the correct voltages are present at the proper locations inside the control panel(s).

Symptom	Possible Cause	Solution
Platform does not rise. Motor does not energize.	Motor overload device tripped.	Reset overload relay or breaker. Determine cause of device tripping.
	Motor starter (three-phase) or motor relay (single-phase) not energizing.	Check voltage at starter or relay coil. <ul style="list-style-type: none"> • If voltage is present and starter or relay does not energize, replace starter or relay. • If voltage is not present, check all components in series with the starter or relay coil.

TROUBLESHOOTING

Symptom	Possible Cause	Solution
Three-phase units only: Platform does not rise. Motor hums, but does not run.	No voltage is present on one line. <i>NOTE: A motor that is missing voltage on one line is said to be single-phased.</i>	Check for blown fuses at branch circuit disconnect. Replace fuse. Determine cause of blown fuse.
		Check motor starter as follows: 1. Disconnect wires at load side of starter. 2. Energize the starter. 3. Measure line-to-line voltage at line side of starter. 4. Measure line-to-line voltage at load side of starter. 5. Line-side and load-side voltages should be approximately the same. Replace starter if voltage values are considerably different from one another.
		Check all wiring to motor for high resistance or no connection.
Three-phase units only: Platform does not rise. Motor runs in reverse	Phase reversed.	Reverse any two legs at the branch circuit disconnect.
Single-phase units only: Platform does not rise. Motor energizes, but does not run.	Line voltage too low.	Check wiring to motor for high resistance. Check for loose or corroded connections. Check if gauge of wires to motor are of correct size and specification for load requirement. Replace if necessary.
	Faulty motor centrifugal switch.	Replace motor.
	Faulty motor capacitor.	Replace motor.
Units equipped with ARTD only: Platform does not automatically return to the cross-traffic position or operates abnormally.	Auto return micro switch not triggering correctly.	Adjust micro switch as necessary. See Adjust Auto Return To Dock (ARTD) on pages 36-37.
	Faulty micro switch.	Replace switch.
	Loose/corroded wire connections or broken wire.	Repair or replace wires and connections as necessary.

TROUBLESHOOTING

Symptom	Possible Cause	Solution
Platform does not rise. Pump operates in pressure relief mode.	Heavy object(s) on platform.	Remove object(s) from platform. Note: For safety reasons, the dock leveler is designed to lift only the platform's own weight.
	Dock leveler binds.	Check for visible obstructions that could cause binding. Remove obstructions. If no obstructions found, contact Systems, LLC Technical Services.
	Pressure relief set too low.	Increase pressure relief. See page 34 for instruction. Note: The pressure relief valve must not be set at a level that causes the motor operating current to exceed the full load amp value* at any time, including when operating in pressure relief. <i>* The full load amp value can be found on the inside cover of the control panel.</i>
Platform rises slowly.	Low hydraulic fluid.	Add fluid, see pages 32-33 for proper fluid level and type.
	Contaminated hydraulic system.	Clean and inspect valves. Flush contaminated oil from hydraulic system. Fill system with new oil. See page 33.
	Damage or blocked hydraulic hose(s) and/or valve(s).	Replace damaged hose(s). Check and remove blockage from hose(s) and/or valve(s).
	Pressure relief set too low.	Increase pressure relief. See page 34 for instruction. Note: The pressure relief valve must not be set at a level that causes the motor operating current to exceed the full load amp value* at any time, including when operating in pressure relief. <i>* The full load amp value can be found on the inside cover of the control panel.</i>
Pump motor loads down when platform reaches the full raised position.	Pressure relief set too high.	Decrease pressure relief. See page 34 for instruction. Note: The pressure relief valve must not be set at a level that causes the motor operating current to exceed the full load amp value* at any time, including when operating in pressure relief. <i>* The full load amp value can be found on the inside cover of the control panel.</i>

TROUBLESHOOTING

Symptom	Possible Cause	Solution
Platform does not rise to full height.	Low hydraulic fluid.	Add fluid, see pages 32-33 for proper fluid level and type.
Lip does not stay extended when leveler lowers.	Flow Control Valve requires adjustment.	Incrementally close Flow Control Valve until system pressure is sufficient to keep lip extended. See page 35 for adjustment instructions.
	Faulty lip cylinder.	Rebuild or replace lip cylinder.
Platform DOES rise to full height, but lip DOES NOT extend or extend fully.	Low hydraulic fluid.	Add fluid, see pages 32-33 for proper fluid level and type.
	Sequence Valve requires adjustment.	Adjust valve as necessary. See page 34 for adjustment instructions.
	The ARTD switch is in the BELOW DOCK position.	Turn the switch to the NORMAL position.
Lip does not extend.	Sequence Valve requires adjustment.	Adjust valve as necessary. See page 34 for adjustment instructions.
Lip extends almost immediately when the RAISE button is Pressed.	Sequence Valve requires adjustment.	Adjust valve as necessary. See page 34 for adjustment instructions.
Platform locks into "safety" as platform lowers. Lip drops to vertical position.	Platform lowering speed is too fast; Flow Control Valve requires adjustment.	Incrementally close Flow Control Valve until platform lowers correctly. See page 35 for adjustment instructions.
	Faulty velocity fuse.	Replace velocity fuse.
	Incorrect or aged hydraulic fluid.	Replace hydraulic fluid, see pages 32-33 for proper fluid level and type.

If additional troubleshooting assistance is required, contact Systems, LLC
Technical Services with equipment serial number or customer order number (CO#).

Technical Service at 800-643-5424 or techservices@loadingdocksystems.com

TROUBLESHOOTING

Hydraulic Schematic

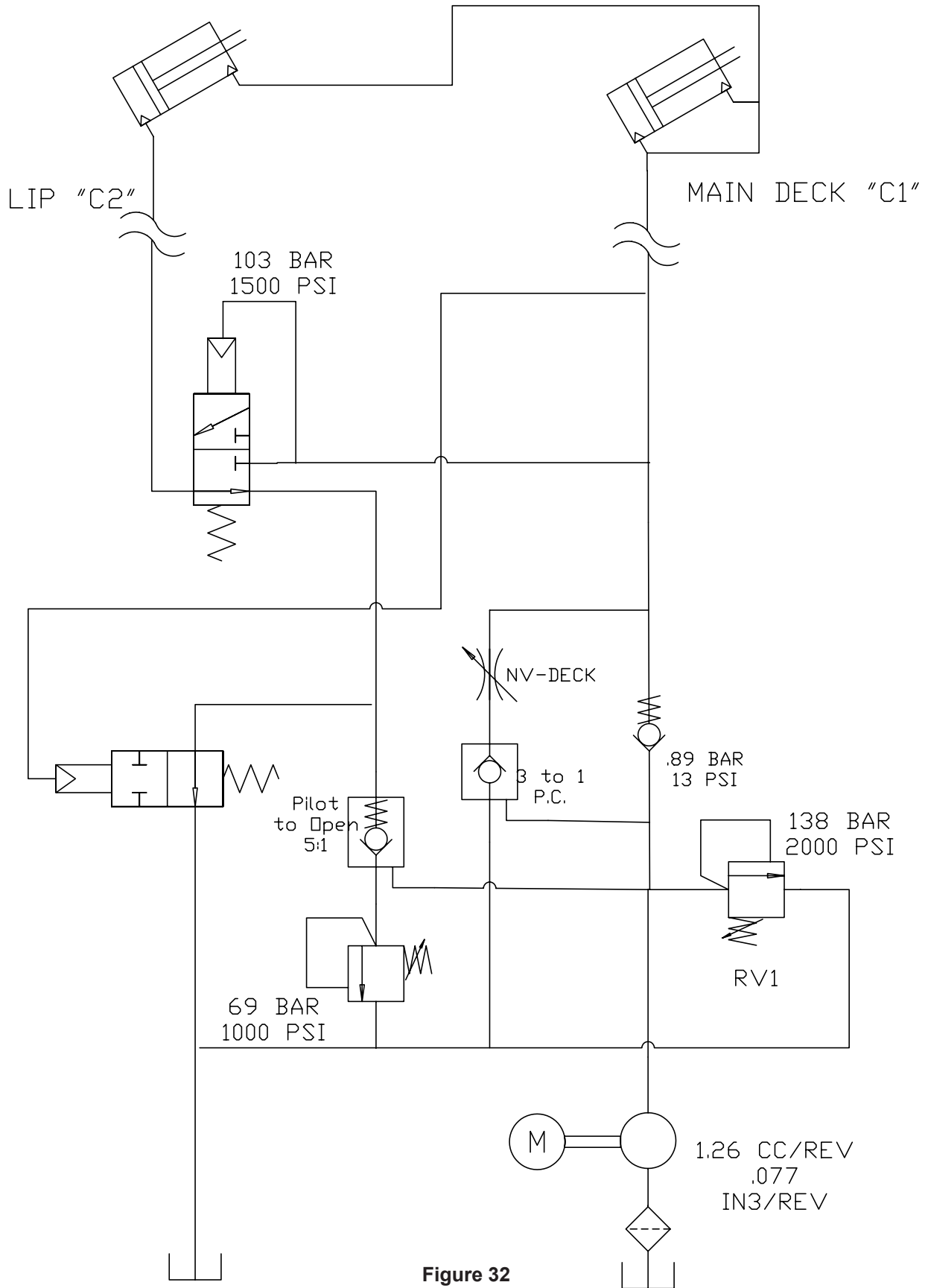

Figure 32

This page intentionally left blank.

PARTS

Danfoss Control Box



Part Number	Voltage	Phase	Description
7141-0268	110v	1-Phase	Danfoss Control Box (MTR 3627A)
7141-0329	208v	1-Phase	Danfoss Control Box (MTR 3627B)
7141-0269	230v	1-Phase	Danfoss Control Box (MTR 3627C)
7141-0310	208v	3-Phase	Danfoss Control Box (MTR 3627D)
7141-0270	230v	3-Phase	Danfoss Control Box (MTR 3627E)
7141-0271	460v	3-Phase	Danfoss Control Box (MTR 3627F)

* Provide dock leveler serial number, voltage, phase, and options when e-mailing, calling or faxing controller orders.

Optional Electrical Parts (Control Box)

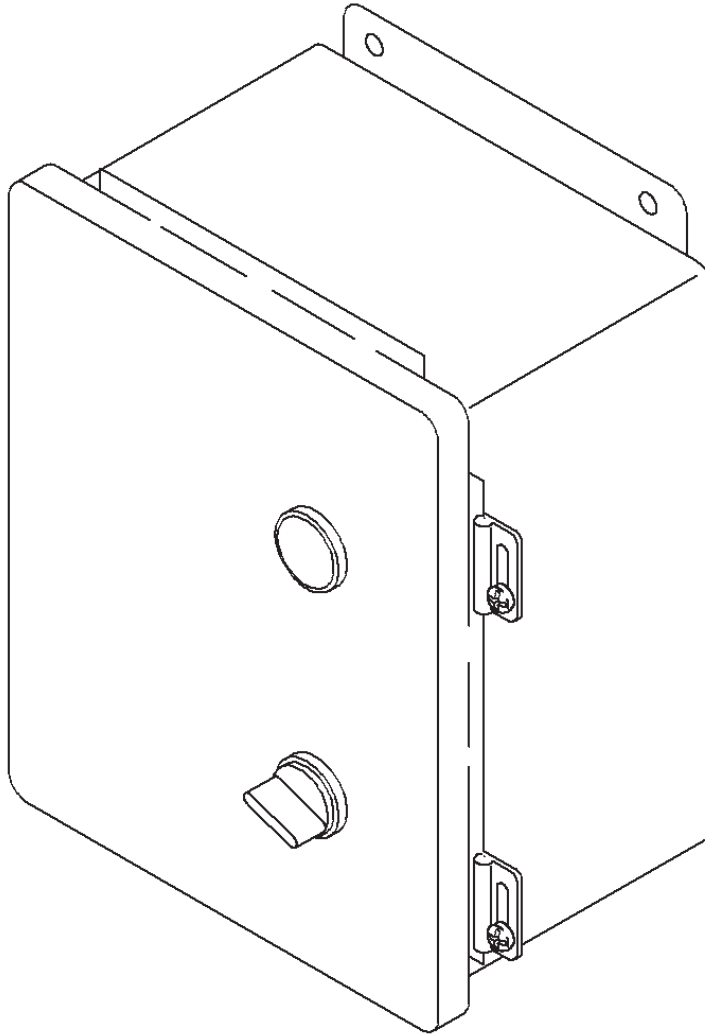

Part Number	Description
CBM1-____*	Control Box w/Optional Equipment

* Provide dock leveler serial number, voltage, phase, and options when e-mailing, calling or faxing controller orders.

PARTS

Optional Electrical Parts (Lip Switch Assembly)

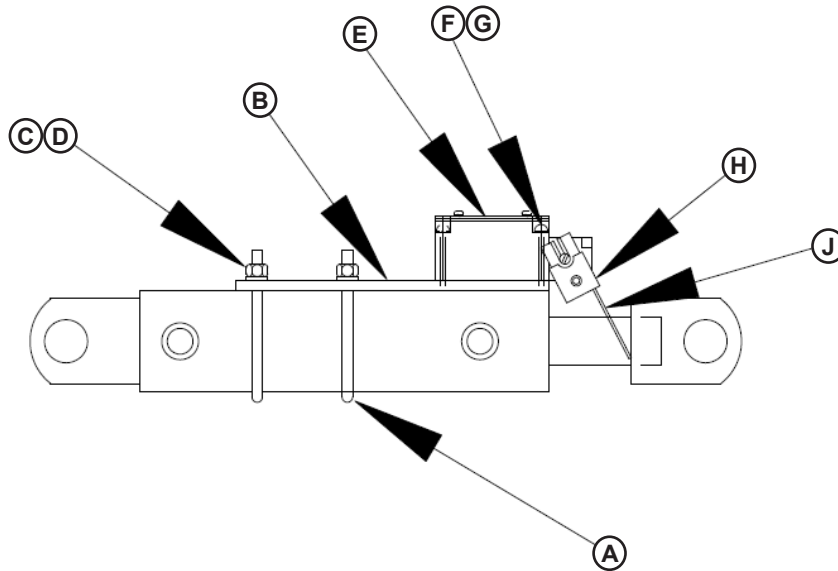

Item	Quantity	Part Number	Description
A	2	M122.012	U-Bolt, 5/16"-18
B	1	M521.613	Switch Plate
C	4	M121.057	Lock Washer, 5/16"
D	4	M121.007	Hex Nut, 5/16"-18
E	1	M112.356	Micro Switch
F	2	M122.074	Bolt, 10-32 x 1-1/2"
G	2	M121.052	Lock Washer, #10 (3/16")
H	1	M112.015	Rod, Actuator
J	1	M521.264	Rod, 1/8" Dia. x 3-1/4"

Optional Electrical Parts (Hoist Switch Assembly)

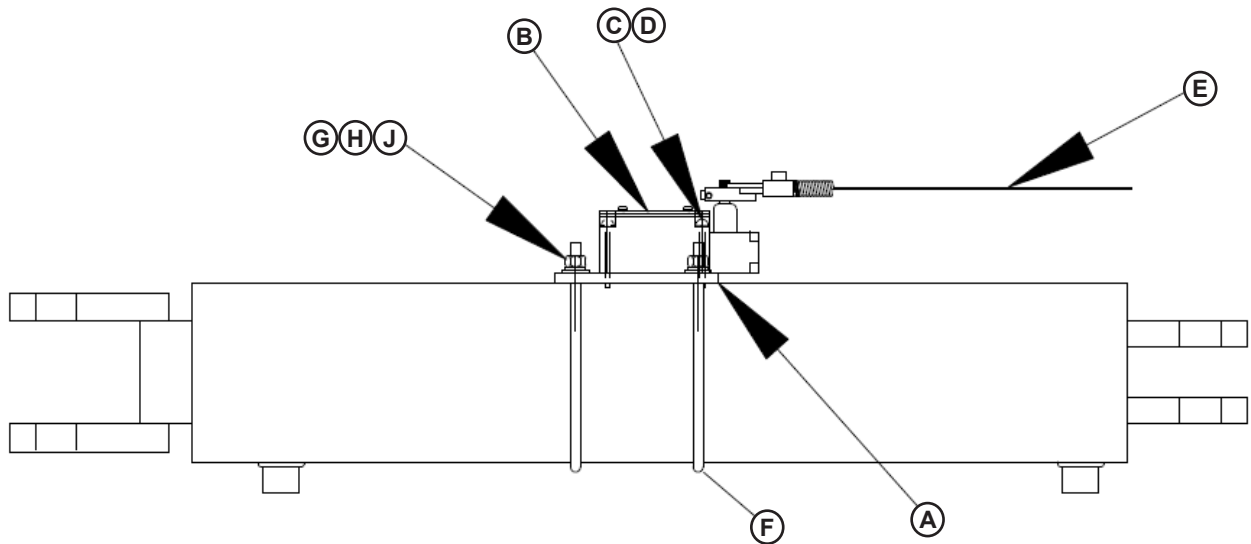

Item	Quantity	Part Number	Description
A	1	M521.389	Main Switch Plate
B	1	M112.253	Micro Switch
C	2	M122.074	Bolt, 10-32 x 1/2
D	2	M121.052	Lock Washer, #10 (3/16")
E	1	M112.176	Arm Lever
3" Hoist Cylinder Models			
F	2	M122.059	U-Bolt, 3/8 x 3-5/8"
G	4	M121.062	Flat Washer, 3/8"
H	4	M121.061	Lock Washer, 3/8"
J	4	M121.010	Hex Nut, 3/8"-16
4" Hoist Cylinder Models			
F	2	M122.058	U-Bolt, 1/4-20 x 5-5/8"
G	4	M121.058	Fender Washer, 9/32"
H	4	M121.056	Lock Washer, 1/4"
J	4	M121.006	Hex Nut, 1/4"-20

PARTS

Frame and Platform

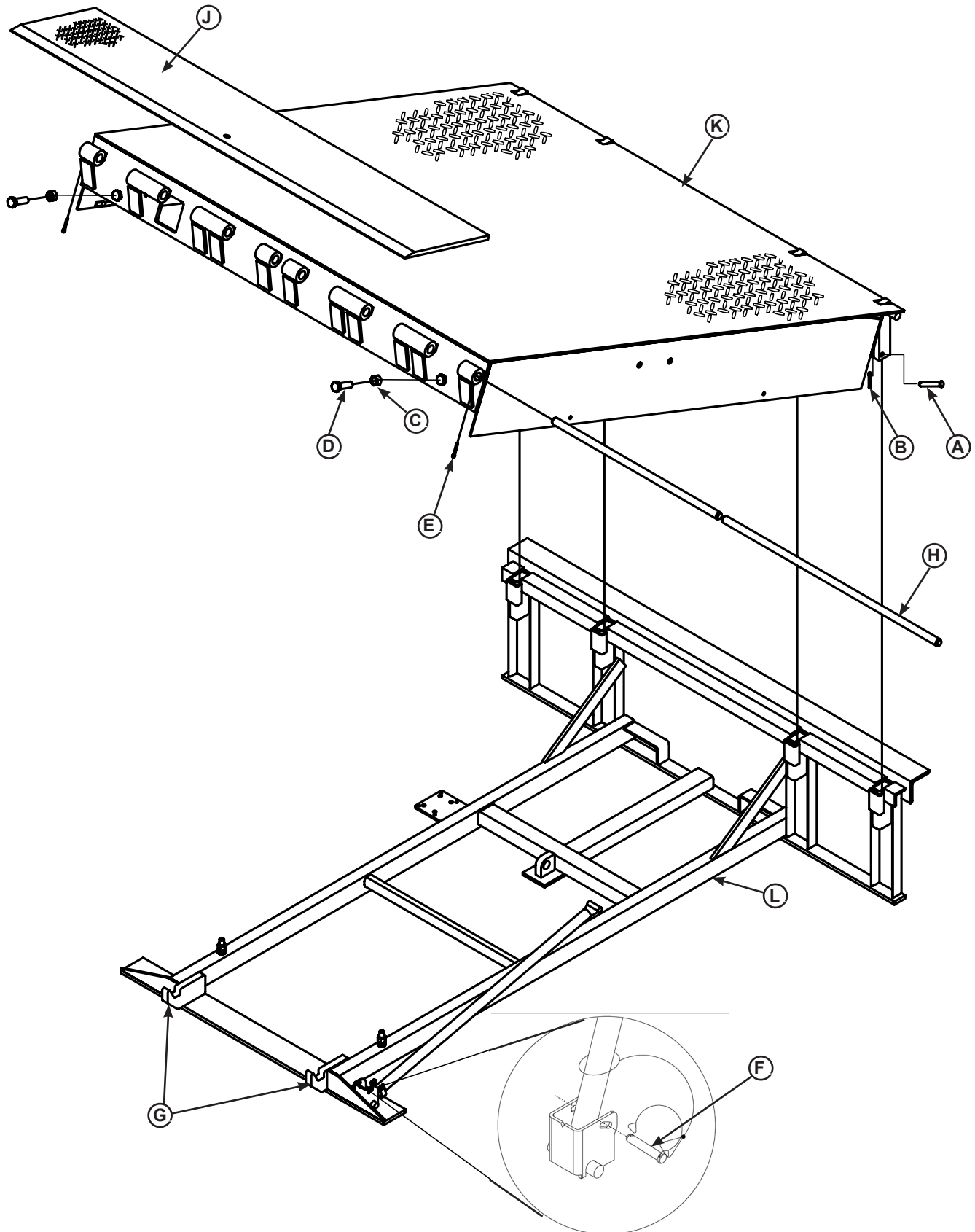

Frame and Platform

Item	Quantity	Part Number	Description
A	4	DOTH-2355	PIN, CLEVIS
B	4	DOTH-2373	PIN, COTTER
C	2	DOTH-2160	NUT, HEX 5/8-11 UNC
D	2	2101-0243	BOLT, 5/8-11 UNC X 2.50 INCH
E	2	DOTH-2382	PIN, COTTER 1/4 X 2
F	1	9201-0006	PROP PIN AND CLIP
G	2	8432-1129	KEEPER LIP 16
		8432-1130	KEEPER LIP 18
		8432-1131	KEEPER LIP 20
		8432-1132	KEEPER LIP 16 (24 PIT)
		8432-1133	KEEPER LIP 18 (24 PIT)
		8432-1134	KEEPER LIP 20 (24 PIT)
H	2	DPLA-2101	LIP SHAFT (6 FOOT)
		DPLA-2102	LIP SHAFT (6.5 FOOT)
		DPLA-2103	LIP SHAFT (7 FOOT)
J	1	See Page 44	LIP
K	1	See Page 44	PLATFORM
L	1	See Page 45	BASE FRAME

¹ Provide dock leveler serial number, platform size, and lip size when calling or faxing orders.

PARTS

Lips

ITEM	6 FOOT							
		25K	30K	35K	40/45K	55K	75K	100K
J	16	0595-5045	0595-5054	0595-5063	0595-5072	0595-5081	0595-5090	0595-5099
	18	0595-5046	0595-5055	0595-5064	0595-5073	0595-5082	0595-5091	0595-5100
	20	0595-5047	0595-5056	0595-5065	0595-5074	0595-5083	0595-5092	0595-5101
	6.5 FOOT							
	16	0595-5048	0595-5057	0595-5066	0595-5075	0595-5084	0595-5093	0595-5102
	18	0595-5049	0595-5058	0595-5067	0595-5076	0595-5085	0595-5094	0595-5103
	20	0595-5050	0595-5059	0595-5068	0595-5077	0595-5086	0595-5095	0595-5104
	7 FOOT							
	16	0595-5051	0595-5060	0595-5069	0595-5078	0595-5087	0595-5096	0595-5105
	18	0595-5052	0595-5061	0595-5070	0595-5079	0595-5088	0595-5097	0595-5106
	20	0595-5053	0595-5062	0595-5071	0595-5080	0595-5089	0595-5098	0595-5107

Platforms

ITEM	6 FOOT			8 FOOT				
		6.0 FOOT	6.5 FOOT	7.0 FOOT		6.0 FOOT	6.5 FOOT	7.0 FOOT
K	25K	9515-5054	9515-5058	9515-5062	25K	9515-5066	9515-5070	9515-5074
	30K	9515-5055	9515-5059	9515-5063	30K	9515-5067	9515-5071	9515-5075
	35K	9515-5056	9515-5060	9515-5064	35K	9515-5068	9515-5072	9515-5076
	40K	9515-5057	9515-5061	9515-5065	40K	9515-5069	9515-5073	9515-5077
	45K	9515-5102	9515-5106	9515-5110	45K	9515-5114	9515-5118	9515-5122
	55K	9515-5103	9515-5107	9515-5111	55K	9515-5115	9515-5119	9515-5123
	75K	9515-5104	9515-5108	9515-5112	75K	9515-5116	9515-5120	9515-5124
	100K	9515-5105	9515-5109	9515-5113	100K	9515-5117	9515-5121	9515-5125
	10 FOOT				12 FOOT			
		6.0 FOOT	6.5 FOOT	7.0 FOOT		6.0 FOOT	6.5 FOOT	7.0 FOOT
	25K	9515-5078	9515-5082	9515-5086	25K	9515-5090	9515-5094	9515-5098
	30K	9515-5079	9515-5083	9515-5087	30K	9515-5091	9515-5095	9515-5099
	35K	9515-5080	9515-5084	9515-5088	35K	9515-5092	9515-5096	9515-5100
	40K	9515-5081	9515-5085	9515-5089	40K	9515-5093	9515-5097	9515-5101
	45K	9515-5126	9515-5130	9515-5134	45K	9515-5138	9515-5142	9515-5146
	55K	9515-5127	9515-5131	9515-5135	55K	9515-5139	9515-5143	9515-5147
	75K	9515-5128	9515-5132	9515-5136	75K	9515-5140	9515-5144	9515-5148
	100K	9515-5129	9515-5133	9515-5137	100K	9515-5141	9515-5145	9515-5149

Base Frames

ITEM	6 FOOT		8 FOOT		10 FOOT 24 INCH PIT		12 FOOT 24 INCH PIT	
L	25K/55K							
	6.0 FOOT							
	16	8435-5027	16	8435-5030	16	8435-5033	16	8435-5036
	18	8435-5028	18	8435-5031	18	8435-5034	18	8435-5037
	20	8435-5029	20	8435-5032	20	8435-5035	20	8435-5038
	6.5 FOOT							
	16	8435-5039	16	8435-5042	16	8435-5045	16	8435-8048
	18	8435-5040	18	8435-5043	18	8435-5046	18	8435-5049
	20	8435-5041	20	8435-5044	20	8435-5047	20	8435-5050
	7.0 FOOT							
	16	8435-5051	16	8435-5054	16	8435-5057	16	8435-5060
	18	8435-5052	18	8435-5055	18	8435-5058	18	8435-5061
	20	8435-5053	20	8435-5056	20	8435-5059	20	8735-5062
	75K(24 INCH PIT)							
	6.0 FOOT							
	16	8435-5063	16	8435-5066	16	8435-5069	16	8435-5072
	18	8435-5064	18	8435-5037	18	8435-5070	18	8435-5073
	20	8435-5065	20	8435-5068	20	8435-5071	20	8435-5074
	6.5 FOOT							
	16	8435-5075	16	8435-5078	16	8435-5081	16	8435-5084
	18	8435-5076	18	8435-5079	18	8435-5082	18	8435-5085
	20	8435-5077	20	8435-5080	20	8435-5083	20	8435-5086
	7.0 FOOT							
	16	8435-5087	16	8435-5090	16	8435-5093	16	8435-5096
	18	8435-5088	18	8435-5091	18	8435-5094	18	8435-5097
	20	8435-5089	20	8435-5092	20	8435-5095	20	8435-5098
	100K (24 INCH PIT)							
	6.0 FOOT							
	16	8435-5099	16	8435-5102	16	8435-5105	16	8435-5108
	18	8435-5100	18	8435-5103	18	8435-5106	18	8435-5109
	20	8435-5101	20	8435-5104	20	8435-5107	20	8435-5110
	6.5 FOOT							
	16	8435-5111	16	8435-5114	16	8435-5117	16	8435-5120
	18	8435-5112	18	8435-5115	18	8435-5118	18	8435-5121
	20	8435-5113	20	8435-5116	20	8435-5119	20	8435-5122
	7.0 FOOT							
	16	8435-5123	16	8435-5129	16	8435-5129	16	8435-5132
	18	8435-5124	18	8435-5127	18	8435-5130	18	8435-5133
	20	8435-5125	20	8435-5128	20	8435-5131	20	8435-5134

PARTS

Hydraulic Components

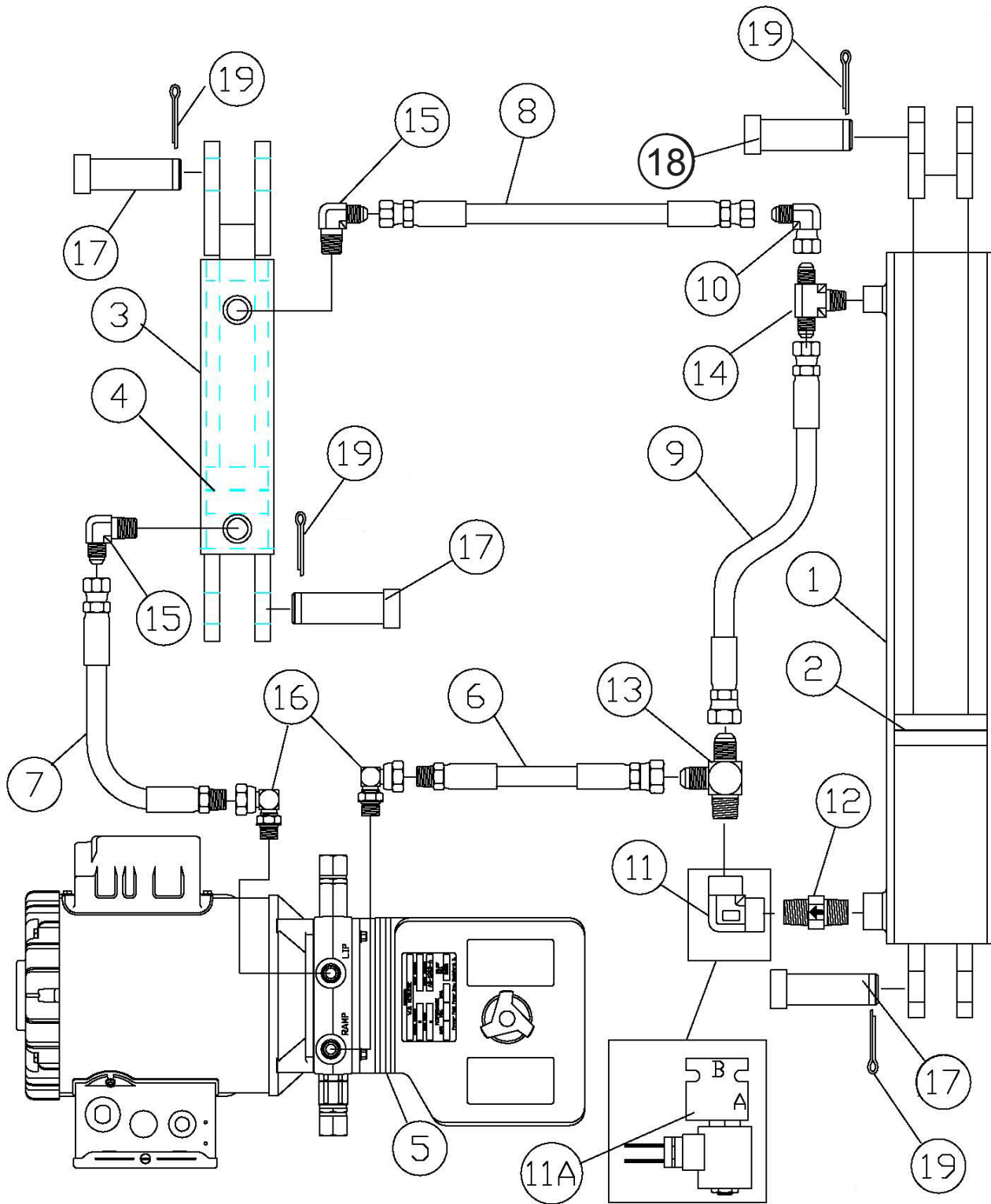

Hydraulic Components

Item	Quantity	Part Number	Description
1	1*	0525-0111	MAIN CYLINDER, 3" BORE x 18" STROKE (All 25k-40k units, 45k-55k 6' units and 8'/10' units w/o Barrier Lip)
	AR*	0525-0112	MAIN CYLINDER, 4" BORE x 18" STROKE (45k-55k 8'/10' units w/Barrier Lip, all 75k-100k units)
2	1	M111.275	SEAL KIT, 3" MAIN CYL. (3" x 18")
	1	M111.274	SEAL KIT, 4" MAIN CYL. (4" x 18")
3	1	0525-0113	LIP CYLINDER
4	1	*	SEAL KIT, LIP CYLINDER
5	1*	M111.374	MOTOR PUMP ASSY. 1-PHASE
		M111.375	MOTOR PUMP ASSY. 3-PHASE
	1*	9391-0055	MOTOR PUMP ASSY. 1-PHASE, DUAL MAIN CYL (not shown) (100k units only)
		9391-0051	MOTOR PUMP ASSY. 3-PHASE, DUAL MAIN CYL (not shown) (100k units only)
6, 7, 8	1*	M811.101	HOSE ASSEMBLY KIT, 6/8 FOOT LEVELERS
6, 7, 8	1*	M811.102	HOSE ASSEMBLY KIT, 10 FOOT LEVELERS
9	1	M111.212	HOSE ASSEMBLY, BOTTOM OF MAIN TO TOP
10	1	M111.170	FITTING, ELBOW SWIVEL
11	1	M111.071	FITTING, ELBOW
11A	1*	M111.206	VALVE, SOLENOID (Units with E-Stop and/or Lip Out)
12	1*	M111.220	FUSE, VELOCITY, 12 GPM (25k-75k units <u>without</u> E-Stop or Lip Out)
	1*	M111.366	FUSE, VELOCITY, 6 GPM (25k-75k units <u>with</u> E-Stop and/or Lip Out)
	2*	DOTH-2871	FUSE, VELOCITY, 2.5 GPM (All 100k units)
13	1	M111.208	FITTING, TEE
14	1	M111.210	FITTING, TEE
15	2	M111.070	FITTING, ELBOW
16	2	DOTH-2738	FITTING, ELBOW SWIVEL
17	AR*	M113.264	PIN, CLEVIS
18	AR*	DOTH-2363	PIN, CLEVIS
19	AR*	DOTH-2382	PIN, COTTER

AR = As Required

* Provide dock leveler serial number, voltage, phase and type of installation when e-mailing, calling or faxing orders.

PARTS

Weather Seals

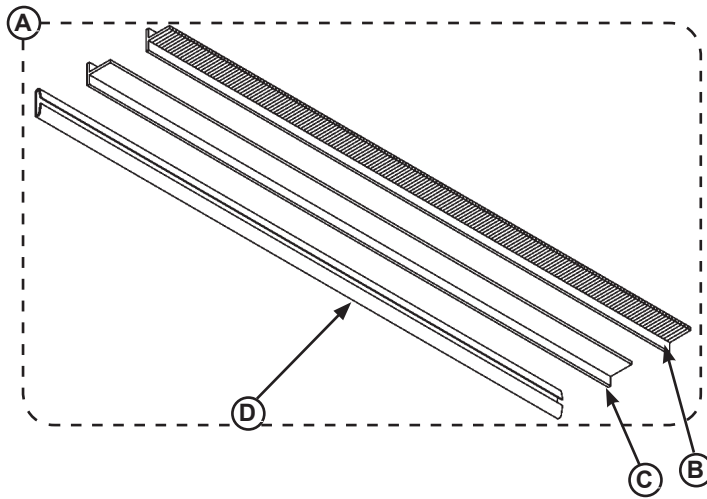

Weather Seal Kits

Item	Quantity	Part Number	Description
A	1	0195-0021	Brush Kit (Includes Seal and Track), 1-1/2 in. 82" Lg. (Both Sides)
	1	0195-0033	Rubber Kit (Includes Seal and Track), 1-1/2 in. 82" Lg. (Both Sides)

Individual Replacement Seals

Item	Quantity	Part Number	Description
B	1	0192-0098	Brush Refill, 1-1/2 in. 82" Lg.
C	1	0192-0085	Rubber Refill, 1-1/2 in. 82" Lg.
D	1	0192-0146	Replacement Channel

* Provide dock leveler serial number and size of platform when e-mailing, calling or faxing orders.

Toe Guards

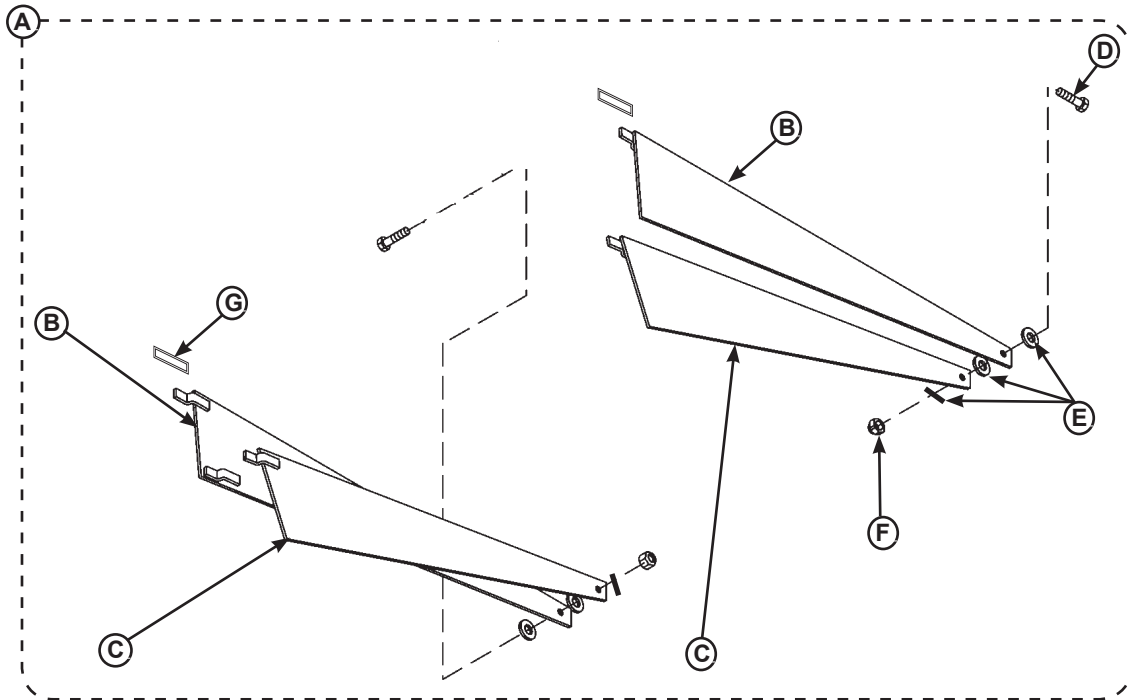

Item	Quantity	Part Number	Description
A	1	DKIT-9183	Toe Guard Kit, Sliding 6' (Includes Both Sides)
		DKIT-9184	Toe Guard Kit, Sliding 8' (Includes Both Sides)
		DKIT-9185	Toe Guard Kit, Sliding 10' (Includes Both Sides)
B	1	0011-0058	Toe Guard, Middle (6 Foot)
		0011-0060	Toe Guard, Middle (8 Foot)
		0011-0062	Toe Guard, Middle (10 Foot)
C	1	0011-0057	Toe Guard, Lower (6 Foot)
		0011-0059	Toe Guard, Lower (8 Foot)
		0011-0061	Toe Guard, Lower (10 Foot)
D	2	DOTH-2043	Cap Screw
E	6	DOTH-2207	Washer
F	2	DOTH-2131	Lock Nut
G	2	0011-0010	Platform Mounting Tab

* Provide dock leveler serial number and size of platform when e-mailing, calling or faxing orders.

MISCELLANEOUS

This page intentionally left blank.

Customer Information

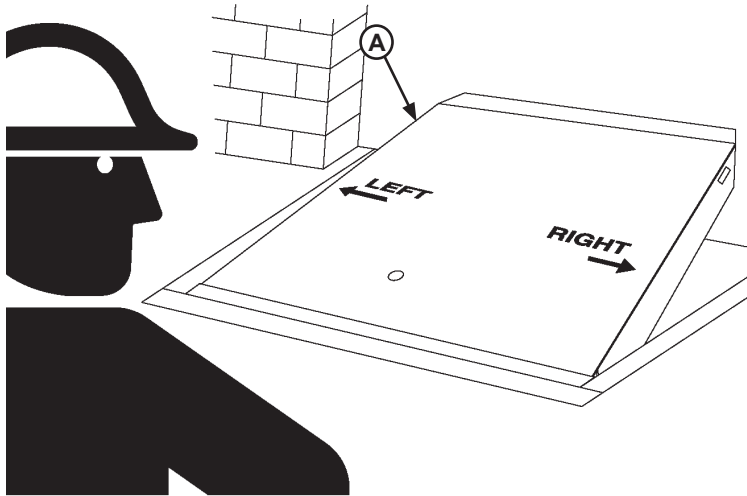

Figure 33

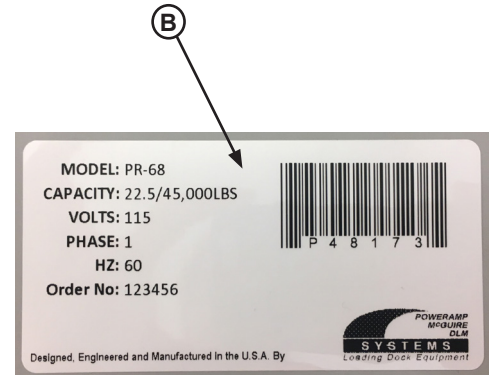

Figure 34

NOTE: Refer to Figure 33 for left/right orientation of dock leveler and Figure 34 for example of decal.

The LEVELER model/serial number decal is located on the left platform joist near the front (lip) of dock leveler (A).

When you receive your new equipment, write down the model and serial number in the form provided. This will help ensure safe keeping of the numbers in the event the model/serial number decal (A, B) becomes lost or damaged.

Also, write down Systems, LLC's order number, the company that installed the dock leveler, and the original owner's name. This will all help to identify the specific dock leveler if more information is required.

When ordering, use part numbers and description to help identify the item ordered. Do not use "item" numbers. These are only for locating the position of the parts. Always give dock leveler MODEL NUMBER and/or SERIAL NUMBER.

For service, call or contact:

Systems, LLC
P.O. Box 309
Germantown, WI 53022

Phone: (800) 643-5424
Fax: (262) 255-5917

www.loadingdocksystems.com

Dock Leveler Information

Model _____

Serial No. _____

Systems, LLC, Job No. _____

Vehicle Restraint Information

Model _____

Serial No. _____

Systems, LLC Order No. _____

Original Owner Information

Name _____

Address _____

Installer Information

Name _____

Address _____

Date of Installation _____

STANDARD PRODUCT WARRANTY

SYSTEMS, LLC warrants that its products will be free from defects in design, materials and workmanship for a period of one (1) year from the date of shipment. All claims for breach of this warranty must be made within 30 days after the defect is or can with reasonable care, be detected. In no event shall any claim be made more than 30 days after this warranty has expired. In order to be entitled to the benefits of this warranty, the product must have been properly installed, maintained and operated in accordance with all manufacturer's recommendations and/or specified design parameters and not otherwise have been subject to abuse, misuse, misapplication, acts of nature, overloading, unauthorized repair or modification, application in a corrosive environment or lack of maintenance. Periodic lubrication, adjustment and inspection in accordance with all manufacturers' recommendations are the sole responsibility of the Owner/User.

In the event of a defect, as determined by SYSTEMS LLC, covered by this warranty, SYSTEMS LLC shall remedy such defect by repairing or replacing any defective equipment or parts, bearing the cost for the parts, labor and transportation. This shall be exclusive remedy for all claims whether based on contract, negligence or strict liability.

WARRANTY LIMITATIONS

THE ABOVE WARRANTIES ARE IN LIEU OF ANY OTHER WARRANTIES, WHETHER EXPRESSED OR IMPLIED, INCLUDING BUT NOT LIMITED TO ANY IMPLIED WARRANTY OF MERCHANTABILITY OR FITNESS FOR A PARTICULAR PURPOSE. SYSTEMS LLC AND ITS SUBSIDIARIES SHALL NOT IN ANY EVENT BE LIABLE TO ANYONE, INCLUDING THIRD PARTIES, FOR INCIDENTAL, CONSEQUENTIAL OR SPECIAL DAMAGES OF ANY KIND INCLUDING BUT NOT LIMITED TO, BREACH OF WARRANTY, LOSS OF USE, LOSS OF PROFIT, INTERRUPTION OF BUSINESS OR LOSS OF GOODWILL.

PRODUCT SPECIFIC WARRANTY "HP/H" SERIES LEVELER

In addition to the "Standard Product Warranty" provided with all McGuire® products, Systems LLC, guarantees materials, components and workmanship to be free of defects for the following extended periods:

- Structural Warranty (HP) – For an additional period of four (4) years, for parts, labor and freight product will carry a **prorated** structural warranty. This warranty specifically applies to; the deck section, lip section, frame, rear hinge assembly and front hinge assembly only.
- Hydraulic Warranty (HP) – For an additional period of four (4) years, for parts, labor and freight, product will carry a **prorated** warranty this warranty specifically applies to; the hydraulic pump and motor, all hydraulic cylinders, hydraulic pressure lines and fittings only.
- Structural Warranty (H) – For an additional period of four (4) years, for parts, labor and freight, this warranty specifically applies to; the deck section, lip section, frame, rear hinge assembly and front hinge assembly only.
- Hydraulic Warranty (H) – For an additional period of four (4) years, for parts, labor and freight, this warranty specifically applies to; the hydraulic pump and motor, all hydraulic cylinders, hydraulic pressure lines and fittings only.